

KERB RAMP WITHOUT TGSIs
PLAN VIEW
 BUILDING OR EDGE OF PAVED WALKWAY.
 N.T.S

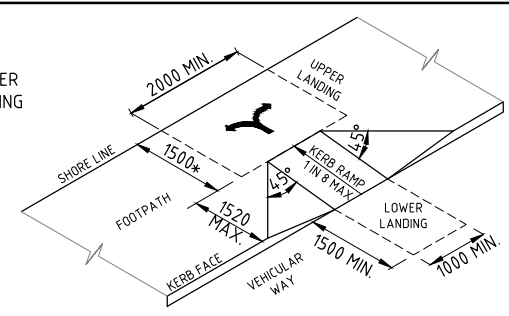

ISOMETRIC VIEW
 N.T.S
 * WHERE THERE IS NO TURN INVOLVED, TOP LANDING MAY BE REDUCED TO 1200mm Min IN LENGTH

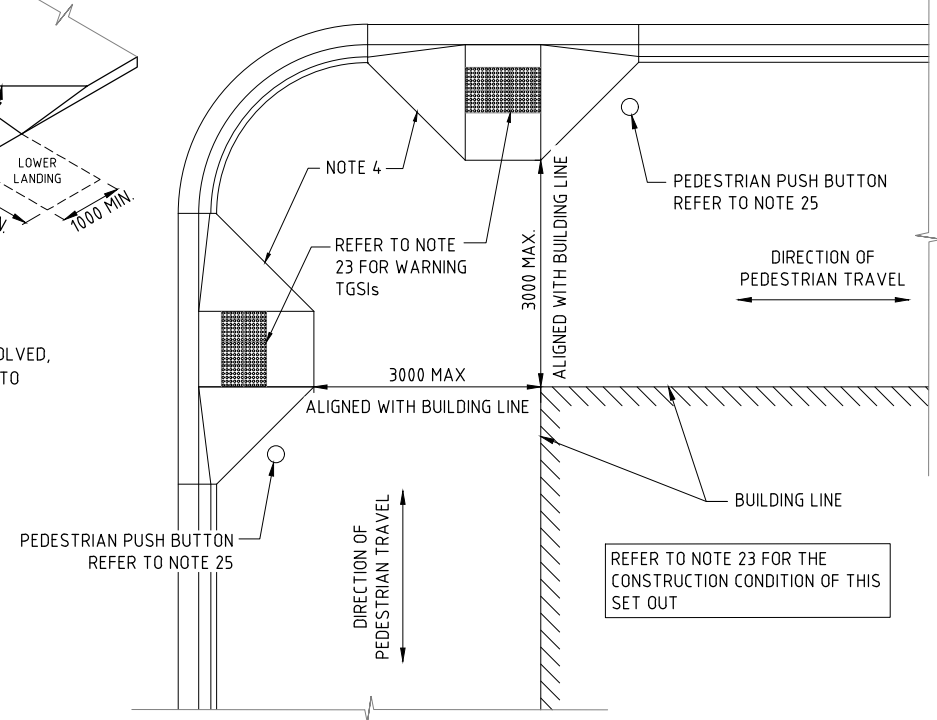

KERB RAMP WITHOUT DIRECTIONAL TGSIs
PLAN VIEW
 N.T.S

NOTES:

- A COMPLIANT KERB RAMP EXISTS WHEN ALL OF THE FOLLOWING ARE SATISFIED:
1. TOP OF RAMP: THERE SHALL BE A MINIMUM OBSTRUCTION FREE WHEELCHAIR TURNAROUND DISTANCE OF 1500mm BEYOND THE TOP OF THE RAMP. THE SHARP TRANSITION AT THE TOP AND BOTTOM OF THE RAMP SHALL BE PERPENDICULAR TO THE DIRECTION OF TRAVEL.
 2. RAMP: MAXIMUM RAMP SLOPE FOR WHEELCHAIR ACCESS SHALL BE 1:8. A SHARP TRANSITION (NO ROUNDING) IS TO BE MAINTAINED AT THE INTERSECTION OF GRADED PLANE SURFACES (TOP AND BOTTOM OF RAMP AND INTERSECTION OF RAMP AND WINGS). THE INTERSECTION OF THE RAMP AND WINGS SHOULD BE TOOLED JOINT.
 3. RAMP ALIGNMENT: RAMP SHALL BE ALIGNED PARALLEL TO THE PEDESTRIAN DIRECTION OF TRAVEL. RAMP ON BOTH SIDES OF A CARRIAGEWAY SHALL BE ALIGNED WITH ONE ANOTHER AND THE DIRECTION OF TRAVEL.
 4. KERB RAMP WINGS: THE REQUIRED WING ANGLE IS 45°. SUBJECT TO THE APPROVAL OF THE SUPERINTENDENT, WINGS MAY BE ANGLED AT LESS THAN 45° IF THE WING IS REQUIRED TO BE CLEAR OF TRAFFIC SIGNAL HARDWARE, OTHER WINGS OR UTILITY PITS/MANHOLES. WING ANGLE MAY ALSO BE REDUCED AT OBTUSE ANGLED INTERSECTIONS. WING WIDTHS SHALL BE 1500 MAX. A SLOPE NO STEEPER THAN 1 ON 4 IS TO BE MAINTAINED ON THE WINGS, AT LEAST A 1 METRE KERB UPSTAND IS DESIRABLE BETWEEN ADJACENT KERB RAMP WINGS ON AN INTERSECTION CORNER.
 5. SURFACE OF THE RAMP: SURFACE OF THE RAMP AND SLOPING SIDES SHALL BE SLIP RESISTANT AS SPECIFIED IN AS/NZS 1428.1-2009.
 6. LANDINGS SHALL BE PROVIDED AS PER AS/NZS 1428.1-2009.
 7. THE MAXIMUM GRADIENT OF A RAMP EXCEEDING 1900mm IN LENGTH SHALL BE 1 IN 14.
 8. KERB RAMP ARE PERMITTED TO HAVE 1:8 SLOPE, PROVIDED THE MAXIMUM RISE IS 190mm AND THE MAXIMUM LENGTH IS NOT GREATER THAN 1520mm.

- TACTILE GROUND SURFACE INDICATORS (TGSIs):
9. AS PER AS/NZS 1428.4.1-2009 CLAUSE 2.2, TACTILE INDICATORS:
 - 9.1. WILL BE DETECTABLE BY TACTILE MEANS.
 - 9.2. SHALL HAVE LUMINANCE-CONTRAST TO THE BASE SURFACE AS FOLLOWS:
 - 9.2.1. WHERE THE INTEGRATES TGSIs ARE OF THE SAME COLOUR AS THE UNDERLYING SURFACE, NOT LESS THAN 30% ACROSS ITS ENTIRE AREA
 - 9.2.2. WHEN DISCRETE TGSIs - NOT LESS THAN 45%
 10. WARNING TGSIs SHALL BE INSTALLED ON OR ADJACENT TO DESIGNATED CROSSING POINTS TO WARN PEDESTRIANS WITH A VISION IMPAIRMENT OF THE IMPENDING HAZARD (TRAFFIC) AND DIRECTIONAL TGSIs SHALL BE INSTALLED TO PROVIDE DIRECTIONAL GUIDANCE IN THE ABSENCE OF DETECTABLE CUES. REFER AS/NZS 1428.4.1-2009 FOR FULL DETAILS OF TGSIs REQUIREMENTS.
 11. TGSIs SHALL BE PROVIDED AT DESIGNATED CROSSING POINTS WHEN NEW DESIGNS OR MODIFICATIONS ARE BEING CARRIED OUT.
 12. DIRECTIONAL TGSIs SHALL BE LAID SO THERE IS NO LIKELIHOOD OF THE EDGES LIFTING.
 13. A DIRECTIONAL TGSIs SHALL BE SLIP-RESISTANT.
 14. DIRECTIONAL TGSIs SHALL HAVE THE TOP SURFACE NO MORE THAN 4mm TO 5mm ABOVE THE BASE SURFACE.
 15. THE BASE SURFACE OF AN INTEGRATED DIRECTIONAL TGSIs SHALL BE NOT MORE THAN 3mm ABOVE THE ABUTMENT SURFACE OF THE SURROUNDING FLOOR OR GROUND SURFACE, AND SHALL HAVE ALL EXPOSED EXTERNAL EDGES CHAMFERED.
 16. DIRECTIONAL TGSIs SHALL BE INSTALLED PARALLEL WITH AND ALONG THE CENTRELINE OF THE REQUIRED DIRECTION OF TRAVEL.
 17. WHERE INTEGRATED DIRECTIONAL TGSIs INDICATE THE CONTINUOUS ACCESSIBLE PATH OF TRAVEL, THEY SHALL BE ARRANGED ACCORDING TO FIGURE 3.1(C) IN AS/NZS 1428.4.1-2009, WITH A DEPTH OF 300mm.
 18. WHERE INTEGRATED DIRECTIONAL TGSIs NEED TO BE DETECTED BY A PERSON APPROACHING AT AN ANGLE TO THE CONTINUOUS ACCESSIBLE PATH OF TRAVEL, THE DIRECTION TGSIs SHALL BE ARRANGED AS SHOWN IN FIGURE 3.1(C) IN AS/NZS 1428.4.1-2009, AND REFER TO STANDARD DRAWING CS3303 FOR THIS NOTE.
 19. WHERE DISCRETE DIRECTIONAL TGSIs ARE USED TO INDICATE A CONTINUOUS ACCESSIBLE PATH OF TRAVEL, THEY SHALL BE ARRANGED IN ACCORDANCE WITH FIGURE 3.1(D) IN AS/NZS 1428.4.1-2009, WITH A MINIMUM OF 4 DISCRETE DIRECTIONAL TGSIs.
 20. WHERE DISCRETE DIRECTIONAL TGSIs NEED TO BE DETECTED BY A PERSON APPROACHING AT AN ANGLE TO THE CONTINUOUS ACCESSIBLE PATH OF TRAVEL, THE DIRECTIONAL TGSIs SHALL BE ARRANGED AS SHOWN IN FIGURE 3.1(D) IN AS/NZS 1428.4.1-2009, WITH A MINIMUM OF 8 DISCRETE DIRECTIONAL TGSIs.
 21. DIRECTIONAL TGSIs TO CONTINUE CUE FOR PEDESTRIANS WITH A VISION IMPAIRMENT.
 22. REFER AS/NZS 1428.4.1-2009 FOR ALL REQUIREMENTS OF TGSIs.
 23. WARNING TGSIs ARE REQUIRED ONLY WHEN THE GRADIENT OF THE KERB RAMP IS LOWER THAN 1 IN 8.5. WHEN THE GRADIENT IS BETWEEN 1 IN 8 AND 1 IN 8.5, NO TGSIs ARE REQUIRED. WHERE THE TOP OF THE RAMP IS MORE THAN 3000 FROM THE BUILDING LINE OR NOT ALIGNED WITH THE BUILDING LINE, DIRECTIONAL INDICATORS ARE ALSO REQUIRED AS PER "KERB RAMP WITH TGSIs".
 24. 300-400, 600-800 DEPTH OF TGSIs PROVIDE VARIANCE FOR THE TYPE OF TILE AVAILABLE.

- GENERAL:
25. FOR LOCATION OF TRAFFIC SIGNALS POSTS, AND LOCATION AND ORIENTATION OF PEDESTRIAN PUSH BUTTON ASSEMBLIES, REFER TO MANUAL OF UNIFORM TRAFFIC CONTROL DEVICES, PART 14. THE PUSH BUTTON POST SHOULD ALSO BE LOCATED ON A LEVEL SURFACE AND THE PUSH BUTTON ASSEMBLY LOCATED WITHIN THE ZONE OF COMMON REACH (REFER AS/NZS 1428.2-1992 i.e. TO BE NO MORE THAN 400mm OUTSIDE THE EDGE OF A PATHWAY OR KERB RAMP).
 26. ALL CONCRETE SHALL BE CLASS N32. ALL CONCRETE TO BE BROOM FINISHED. RAMP TO BE CAST MONOLITHICALLY WITH THE CHANNEL OR TRAY.
 27. ALL DIMENSIONS ARE IN MILLIMETERS UNLESS NOTED OTHERWISE.
 28. HANDRAILS SHALL BE IN ACCORDANCE WITH AS/NZS 1428.1-2009 AND STAINLESS STEEL FINISH TO ALL RELEVANT AUSTRALIAN STANDARDS.

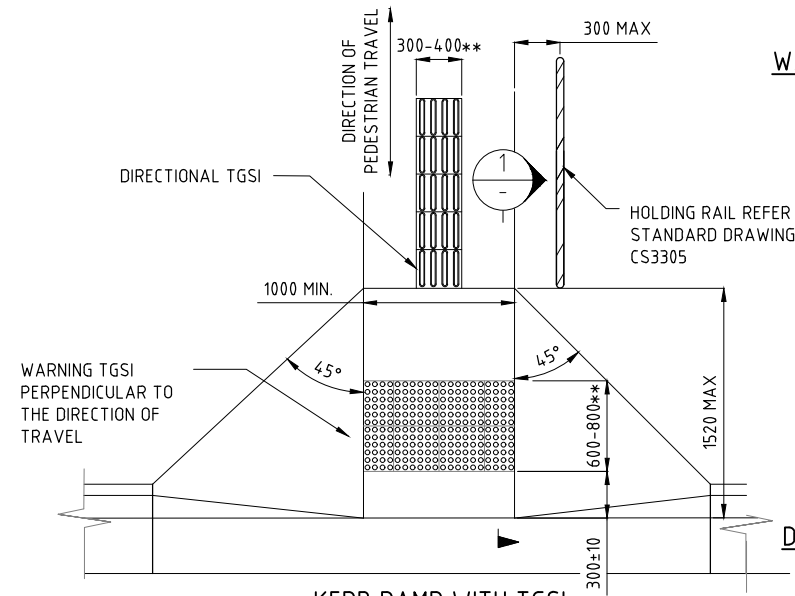

KERB RAMP WITH TGSIs
PLAN VIEW
 N.T.S

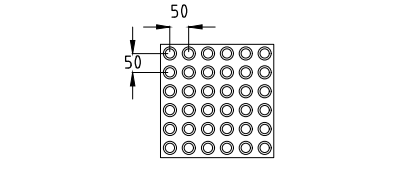

WARNING TGSIs PATTERN DETAIL
PLAN VIEW

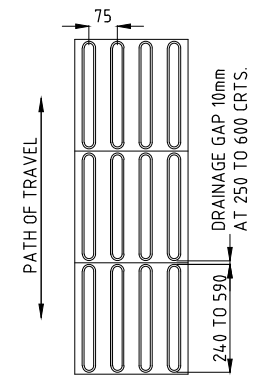

DIRECTION TGSIs PATTERN DETAIL
PLAN VIEW

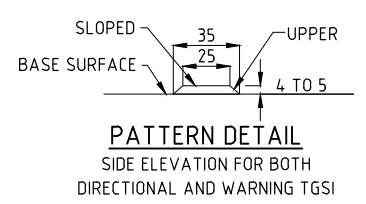

PATTERN DETAIL
 SIDE ELEVATION FOR BOTH DIRECTIONAL AND WARNING TGSIs

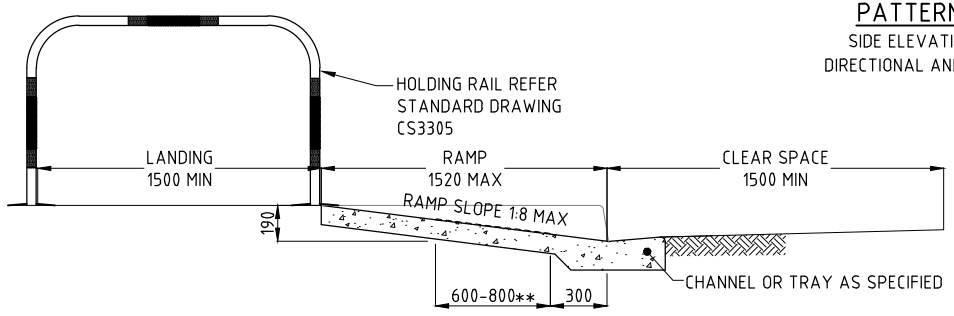

SECTION 1
 NOT TO SCALE

** REFER TO NOTE 24

** REFER TO NOTE 24

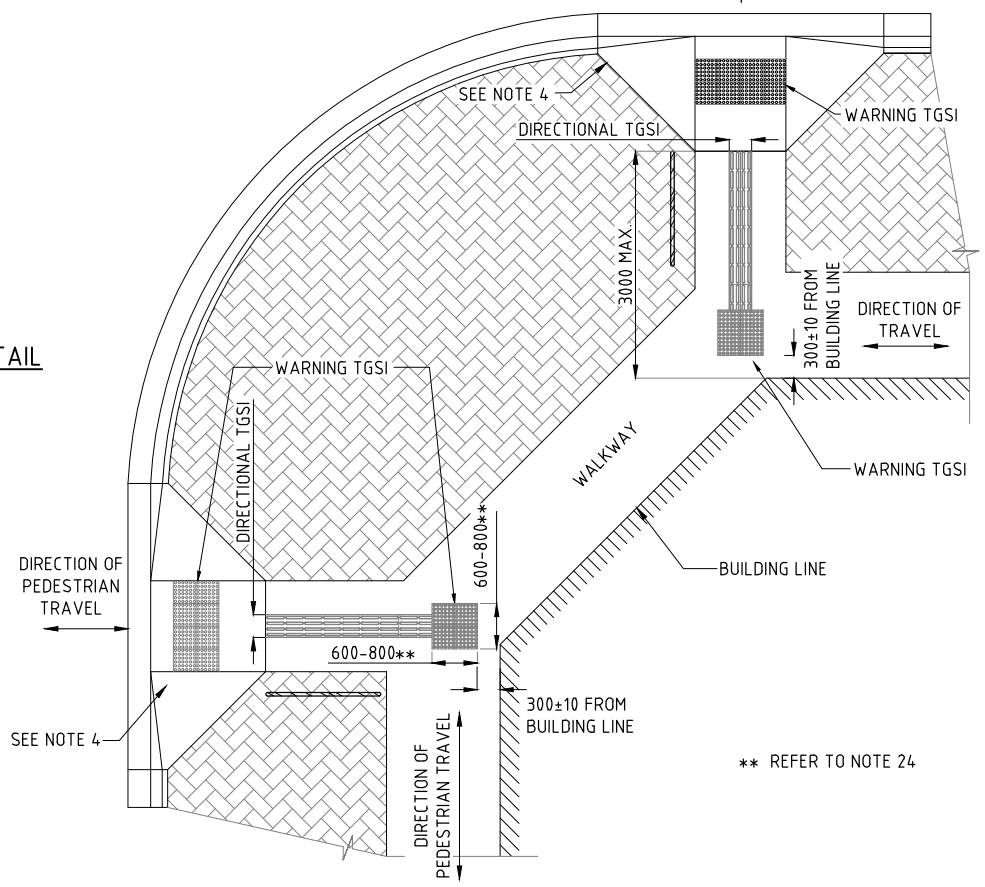

KERB RAMP WITH TGSIs
PLAN VIEW
 N.T.S

WARNING

BEWARE OF UNDERGROUND SERVICES. THE LOCATIONS OF UNDERGROUND SERVICES ARE APPROXIMATE ONLY AND THEIR EXACT POSITION SHOULD BE PROVEN ON SITE. NO GUARANTEE IS GIVEN THAT ALL EXISTING SERVICES ARE SHOWN.

| No. | DESCRIPTION | DATE | NAME | DEPT/COMPANY |
|-----|-------------------------------|-----------|----------|--------------|
| 2 | MINOR CHANGE - DIMENSION LINE | MAY 2019 | S.SHI | EES/DIPL |
| 1 | DESIGN DETAILS UPDATED | MAR 2019 | S.SHI | EES/DIPL |
| 0 | ISSUED AS A STANDARD DRAWING | SEPT 2017 | J.LEESON | EES/DIPL |

| | | | |
|---------------|-----------|-----------------|-----------|
| DRAWN | J.LEESON | CHECKED | S.HATZI |
| DATE | JUNE 2017 | DATE | JUNE 2017 |
| DESIGNED | | CHECKED | |
| DATE | | DATE | |
| DESIGN LEADER | S.HATZI | DESIGN DIRECTOR | S.JACKSON |
| DATE | 1/09/2017 | DATE | 1/09/2017 |



| | | | |
|------------------------------------------|-----------|-----------|-------------|
| STANDARD DRAWINGS | | | |
| KERBING, FENCING & LANDSCAPING | | | |
| TACTILE GROUND SURFACE INDICATOR (TGSIs) | | | |
| SHEET 1 - KERB RAMP | | | |
| FILE No. | ASSET No. | SHEET No. | DRAWING No. |
| - | - | 1 OF 1 | CS3302 |
| | | | AMEND. |
| | | | 2 |
| | | | SHEET SIZE |
| | | | A1 |