



## MATERIALS TESTING MANUAL



Originator: <i>Philip Stacey, Senior Project Manager, Materials Testing</i>	Approved by: <i>Bob Pemble, Executive Director, Civil Construction</i>	Approved for Intranet Publication: <i>4 November 2013</i>
Controlled Document Number: QM 0182	Version Number: V0.1	Review by: 20 September 2014

## CONTENTS

### SECTIONS

- SECTION 1 - CODES OF PRACTICE
- SECTION 2 - SAMPLING AND TESTING SOILS
- SECTION 3 - SAMPLING AND TESTING AGGREGATE
- SECTION 4 - SAMPLING AND TESTING PAVEMENT MARKING AND TRAFFIC CONTROL DEVICES
- SECTION 5 - SAMPLING AND TESTING BITUMEN AND RELATED PRODUCTS
- SECTION 6 - SAMPLING AND TESTING CEMENT AND CONCRETE
- SECTION 7 - PAVEMENT TESTING
- SECTION 8 - AUSTRALIAN STANDARDS AND OTHER PUBLICATIONS COVERED UNDER THE DEPARTMENT OF PLANNING AND INFRASTRUCTURE ROADWORKS SPECIFICATION
- SECTION 9 - NOT USED
- SECTION 10 - NOT USED

## INDEX OF CODES OF PRACTICE

METHOD NO.	SECTION 1 – METHOD CODE OF PRACTICE	PAGE NUMBER
NTCP 101.1	Selection of Test Methods	2
NTCP 102.1	Testing Field Compaction for Conformance	3
NTCP 103.1	Site Selection by the Stratified Random Technique	11
NTCP 105.2	Audit Testing of Compaction - Joint Method	16
NTCP 106.1	Registration of Asphalt Mix Designs	18
NTCP 107.1	Ride Quality	22

## SELECTION OF TEST METHODS

### 1. SCOPE

This Code covers the selection of the most appropriate test method for sampling or testing of materials.

The Northern Territory Department of Infrastructure Test Methods (NTTM) and Codes of Practice (NTCP) have been developed to clearly identify the practice to be adopted.

### 2. SELECTION OF TEST METHOD

The Department of Infrastructure Test Methods and Codes of Practice contained in this Materials Testing manual shall take precedence over all test methods and procedures, and shall be used in conjunction with relevant Australian Standards.

Where tests are required which are not included in the manual, the appropriate Australian Standard method shall be used. In special circumstances where tests are required which are not covered in this manual or by Australian Standards, other appropriate methods may be used at the Superintendent's approval, i.e.

Australian Road Research Board	(ARRB)
Austroads	(Austroads)
National Association of Australian State Road Authorities	(NAASRA)
British Standards Institution	(BSI)
American Society for Testing Materials ASTM	(ASTM)

## TESTING FIELD COMPACTION FOR CONFORMANCE

### 1. SCOPE

This Code sets down the procedures to be followed when carrying out acceptance testing of field compaction of pavement materials, earthworks and backfill.

This Code takes precedence over Australian Standards.

For work being carried out under contract, this Code must be read in conjunction with the particular contract specification and relevant test methods.

### 2. LOT TESTING

#### 2.1 Test Lot Bounds

Test lot bounds shall be determined by the contractor in accordance with the specification. Areas within 150mm of the edges of construction, or within 5 metres of lateral construction joints should be excluded from the lot.

Soils and pavement materials which do not appear essentially homogenous and are not uniform in terms of maximum size and particle size distribution may be included in the lot provided that laboratory compaction tests are performed on material from each field density test site ie one for one testing.

#### 2.2 Selection of a Lot

It is the responsibility of the Superintendent or, on quality system contracts, the contractor, to define the bounds of the lot, to designate any areas to be excluded from the lot on the basis of appearance or test-rolling response and to nominate any areas, excluded under Section 2.1 which is required to be assessed separately.

#### 2.3 Selection of Test Sites within a Lot

The validity of lot testing depends on there being no bias associated with the selection of test sites. Prior to the start of the selection process, every point in the lot must have an equal chance of being selected.

The method for selecting the test sites is covered in NTCP 103.1 - Site Selection by the Stratified Random Technique.

### 3. FIELD DENSITY MEASUREMENT

Different methods shall not be used in the determination of field densities within a lot.

The following test methods are currently applicable:

### 3.1 Test Methods

Department of Infrastructure Test Methods and Codes of Practice.

Australian Standard Test Methods:

- AS1289.2.1.1 - Determination of the Moisture Content of a Soil - Oven Drying Method;
- AS1289.5.2.1 - Determination of the Dry Density Moisture Content – Relation of a Soil Using Modified Compactive Effort;
- AS1289.5.4.1 - Dry Density Ratio, Moisture Ratio and Moisture Variation;
- AS1289.5.4.2 - Assignment of Maximum Dry Density and Optimum Moisture Content Values;
- AS1289.5.8.1 - Determination of Field Moisture Content and Field Dry Density of a Soil – Method Using a Nuclear Surface Moisture - Density Gauge - Direct Transmission Mode;
- AS 1289.5.8.4 - Nuclear Surface Moisture – Density Gauges – Calibration Using Standards Blocks.

The job specification must be checked to see whether or not acceptance is based on testing of the work in lots.

### 3.2 Selection of Test Methods

Nuclear gauges shall be used for the determination of field density. When environmental conditions are such that the results from the nuclear gauge could be affected, at the superintendent's approval alternative methods may be considered.

Whenever practicable, the same method shall be used for all field density testing carried out on a given material on any one project.

Results from different modes of operation are not comparable.

### 3.3 Nuclear Gauge Testing

For earthworks and pavement materials, nuclear gauge testing shall be performed in accordance with AS 1289.5.8.1.

### 3.4 Depth of Testing

The depth over which density testing is carried out by Nuclear Gauge in the direct transmission mode, shall be with the probe set at a point equal to, or as near as practicable to the nominal layer thickness.

**NOTE:** Should the probe be inserted to a depth greater than the nominal layer thickness the test must be repeated. This can be checked when collecting samples for moisture contents for processing by AS1289.2.1.1.

### 3.5 Moisture Content

Field moisture content may be determined by either a nuclear gauge in accordance with AS 1289.5.8.1, using offsets determined in accordance with AS 1289.5.8.4, when applicable, or AS 1289.2.1.1.

When the moisture content is determined by AS 1289.2.1.1, the sample shall be taken from between the source rod and the detector to the depth of the probe. The sides of the hole shall be reasonably vertical.

## 4. ESTABLISHMENT OF REFERENCE DENSITY FOR CALCULATION OF DENSITY RATIO USING MODIFIED COMPACTION

### 4.1 Test Methods

This method shall be used in conjunction with relevant Australian Standards and Department of Infrastructure Test Methods.

Variable quality (heterogenous) materials, for example most naturally occurring materials, shall be tested using one for one testing in accordance with Australian Standard AS 1289.5.4.1.

Uniform quality (homogeneous) materials, for example processed materials such as fine crushed rock, and may be tested in accordance with Australian Standard AS 1289.5.4.2.

#### **NOTES:**

- (a) A laboratory compaction test should be performed for each field density determination (one for one);
- (b) A mean MMDD shall NOT be used to calculate the dry density ratio, or relative compaction;
- (c) Under no circumstances should samples of material taken from two or more field density test sites be combined and then used for laboratory compaction;
- (d) Under no circumstances should samples of material be taken from windrows or stockpiles for compaction testing;
- (e) The maximum dry density shall be adjusted for oversize when appropriate.

### 4.2 Stabilised Materials

#### 4.2.1 Cement - Stabilised Materials

Laboratory compaction tests should be carried out on material sampled prior to field compaction and laboratory compaction should be carried out within 2 hours of mixing with cement. It is desirable to cure the stabilised laboratory sample for 30 minutes prior to laboratory compaction. Preparation of samples for laboratory compaction shall be in accordance with AS 1289.1 and Test Method NTTM 201.3.

#### 4.2.2 Lime - Stabilised Materials

Laboratory compaction tests should be carried out on samples taken from the road-bed immediately after compaction and the laboratory compaction shall be carried out within 24-48 hours of field mixing. Preparation of samples for compaction shall be in accordance with AS 1289.1 and Test Method NTTM 201.2.

## 5. OVERSIZE MATERIAL

Oversize material is defined as any material which is coarser than the maximum size allowed in the laboratory compaction test AS1289.5.2.1. The mould size for laboratory compaction test is determined based on the oversize materials present in the moisture content sample. Determine the oversize correction in accordance with AS1289.5.4.1.

## 6. CALCULATION OF MEAN AND CHARACTERISTIC VALUES OF DENSITY RATIO IN LOT TESTING

A minimum of 3 tests shall apply to any lot submitted for testing. Two methods are available for calculation of the Dry Density Ratio for determining the conformance of a lot. The method to be selected is based on the number of tests within a lot.

**3-5 tests;** Determine the **Mean Dry Density Ratio** in accordance with section 6.1

**6 or more tests;** Determine the **Characteristic Mean Dry Density Ratio** in accordance with section 6.2.

**All test results from a lot must be included in the calculations, including those markedly different from the average.**

### 6.1 The Mean Dry Density (R)

Is calculated as follows:

$$R = \frac{\text{sum of } x_i}{n}$$

Where R = mean dry density ratio for the lot,

$x_i$  = an individual test result, and

n = the number of results in the lot.

When less than 6 tests are used to determine compliance of a lot, the Mean Dry Density Ratio only is used.

### 6.2 The Characteristic Mean Dry Density Ratio ( $R_c$ )

Firstly calculate the standard deviation and the mean of the sample. Then determine if there are any outliers. An outlier is any density ratio result which is more than 2.5 standard deviations away from the mean. All outliers shall be removed from the calculation of the characteristic mean dry density ratio.

All results including means and standard deviations shall be recalculated after removing any outliers. The procedure for removing outliers shall then be rechecked as above.

If after removing any outliers the number of tests involved is reduced to less than 6, the Dry Density Ratio shall be determined in accordance with the **Mean Dry Density Ratio** specification requirements, and not the **Characteristic Mean Dry Density Ratio** specification.



The Standard Deviation/s is defined as the Distribution of the Dry Density Ratio of a lot, calculated as follows:

$$s = [\text{sum of } (x_i - R)^2 \text{ divided by } (n - 1)]^{0.5}$$

Where  $x_i$  = an individual test result,  
 $R$  = the mean of  $n$  results, and  
 $n$  = the number of test results in the lot.

$R_c$  is then calculated as follows:

$$R_c = R - ks$$

Where  $R_c$  = the characteristic mean dry density ratio for the lot,  
 $k$  = the multiplier in Table 1, and  
 $s$  = the standard deviation.

## 7. RETESTING OF WORK

### 7.1 Retesting of a Lot

Retesting should only be undertaken after reworking or corrective action and not merely on the basis of the test results. When retesting is carried out, then the Superintendent shall be informed.

Values of Maximum Dry Density and Optimum Moisture Content shall be determined again for each field density as the material has been reworked.

### 7.2 Repeat Testing to Recheck a Result

Repeat testing should be undertaken only if an error is known or suspected to have occurred in the testing procedures, or if an outlier has been identified. A replacement result can be obtained by random selection of a test site within the relevant stratum of the lot. If the volume of retesting is greater than one test or one stratum, discard all testing and obtain a new set of random numbers and retest the entire lot.

Any stratum within a lot which has not been included in the assessment of **Characteristic Mean Dry Density Ratio** for any reason shall be identified as a separate lot and tested independently.

## 8. SPECIFICATIONS NOT BASED ON LOT TESTING

Some job specifications may simply stipulate that the material on specific areas, which do not constitute part of a lot, must be compacted to not less than a certain percentage of density ratio based on modified compactive effort. In these cases the Superintendent must be consulted as to the number of test sites required and to the manner in which they are to be located.

## 9. REPORTING

Compaction test reports shall contain;

- i) All test results from a lot including:
  - Those markedly different from the means, Outliers, Retests, and;
  - Repeat tests due to sampling or testing errors;
- ii) All compaction curve graphs when requested, and;

- iii) Copies of the stratified random selection worksheet used for selection of test site locations;
- iv) Mean dry density ratio or characteristic mean dry density ratio as appropriate.

**FLOWCHART**

**DETERMINATION OF LABORATORY COMPACTION METHOD**

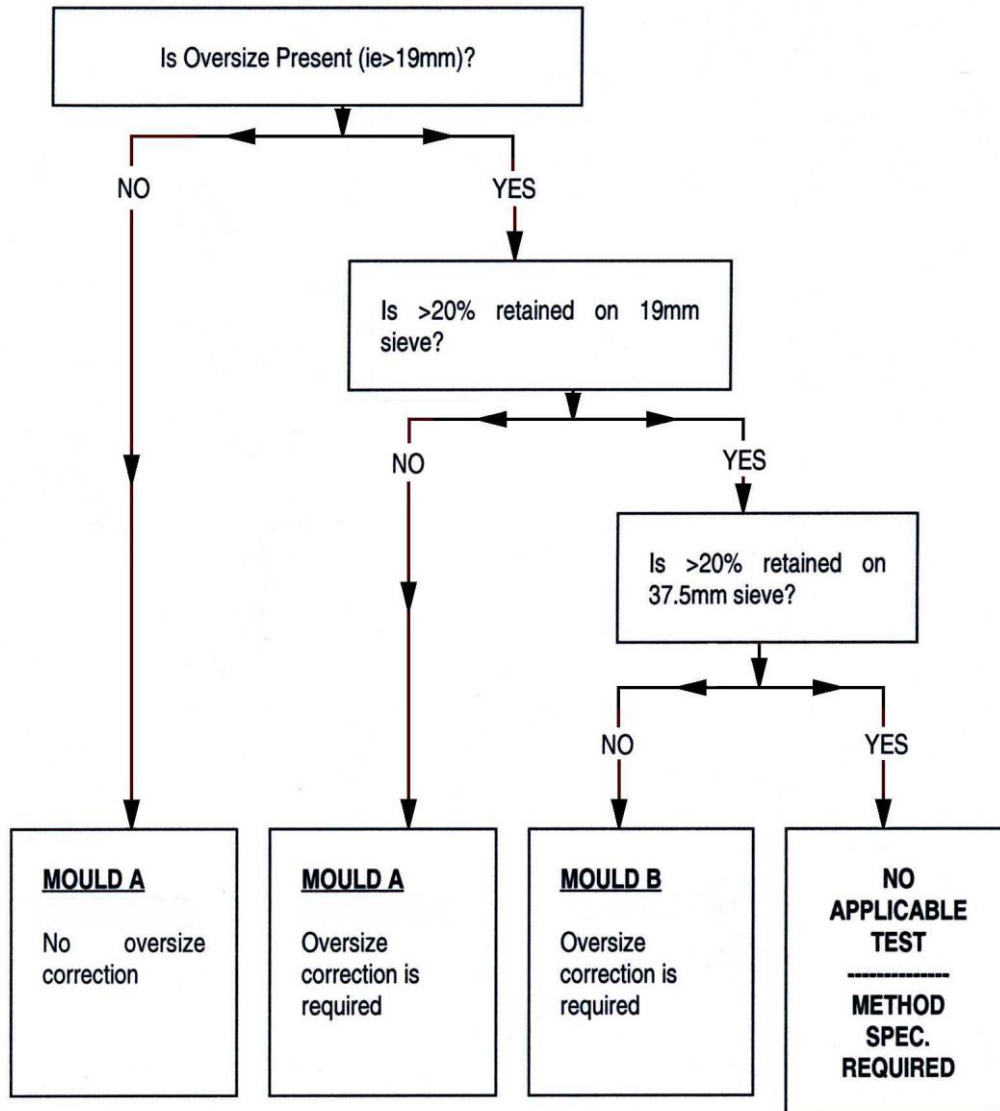

**NOTE:** When necessary, recombine the material passing the 37.5mm sieve and that passing the 19mm sieve and thoroughly mix.

**TABLE 1**

**VALUES OF THE MULTIPLIER k FOR CHARACTERISTIC MEAN DRY DENSITY RATIO (R<sub>c</sub>)**

Number of test per lot (n)	k
6	0.50
7	0.54
8	0.56
9	0.59
10	0.61
15	0.68
20	0.72

**PAVEMENT CONFORMANCE CRITERIA**

**EXAMPLE ONLY**

The following examples demonstrate the application of pavement conformance criteria.

- Xi = an individual test result
- R = mean of n results
- n = number of tests
- k = multiplier
- s = standard deviation

$$R = \frac{\text{Sum of } X_i}{n}$$

$$R_c = R - ks$$

$$s = [\text{Sum of } (X_i - R)^2 \text{ divided by } (n-1)]^{0.5}$$

**WHEN SIX (6) OR MORE, TESTS ARE USED TO DETERMINE COMPLIANCE OF A LOT**

**EXAMPLE 1A**

<b><u>n</u></b>	<b><u>X<sub>i</sub></u></b>		
1	100.1%	R = <u>599.1%</u>	R = 99.85%
2	99.6%	6	
3	101.1%	s = 0.734166	
		k = 0.5 (for six tests)	
4	99.1%	R <sub>c</sub> = 99.85% - (0.5 x 0.734166)	
5	100.0%		
6	99.2%	R <sub>c</sub> = 99.48%	R <sub>c</sub> = 99.5% (rounded to 0.1%)
	-----		
Sum	599.1%		

**EXAMPLE 1B**

<b>n</b>	<b>Xi</b>		
1	100.1%		
2	97.2%		
3	102.4%	R = <u>802.3</u>	R = 100.29
4	101.1%	8	
5	103.1%	s = 1.9372	
6	98.8%	k = 0.56 (for eight tests)	
7	100.5%		
8	99.1%	Rc=100.29% - (0.56 x 1.9372)	
	-----	Rc= 99.20%	Rc = 99.2% (rounded to 0.1%)
Sum	802.3%		

Compliance/rejection will be judged on current Department specifications. An example is included in Table 2 Column B.

**NOTE:** The effect of the standard deviation on the mean density ratio is as follows. Small standard deviations will have small effects. Large standard deviations will have a significant effect.

**WHEN LESS THAN SIX (6) TESTS ARE USED TO DETERMINE COMPLIANCE OF A LOT**

**EXAMPLE 2A**

<b>n</b>	<b>Xi</b>	R = <u>Sum of Xi</u>	
1		100.1%	n
2		99.2%	
3		101.1%	R = <u>499.5%</u>
4	99.1%		5
5		100.0%	R = 99.9% R = 99.9% (rounded to 0.1%)
		-----	
Sum		499.5%	

Compliance/rejection will be judged on current Department specifications. An example is attached in Table 2 Column A.

## SITE SELECTION BY THE STRATIFIED RANDOM TECHNIQUE

### 1. SCOPE

This Code sets out the procedure to be followed in selecting sites of a 2-dimensional lot by a stratified random technique. Stratified random sampling consists of stratifying the lot into subdivisions and then randomly selecting a sample from each subdivision.

### 2. PROCEDURE

- (a) Determine the width, length and area of the lot;
- (b) Determine the number of test samples required in the lot in accordance with the specification. Divide the lot into sub-lots (stratum) of approximately equal areas, such that there is one sub-lot for each test sample required;
- (c) Number the strata as Strata 1, Strata 2, Strata 3 etc;
- (d) Place the point of a pencil or other marker blindly on the page of random numbers. (See Sheet 5);
- (e) Select a starting point from the first digit (after the decimal) of this number as our column number, and the second and third digits as our row numbers;

Example: Starting Point = 0.271 (Selected blindly)

Column = 2

Row = 71

- (f) Select the first random number by going to the column and row selected above;
 

Example: Column 2, row 71, random number = 0.846. This will be used to determine our (y) coordinate for site 1 in stratum 1;
- (g) Two random numbers from Table of Random Numbers are required to locate each test site within each stratum. So select the second random number by proceeding vertically down the column to the next number and select this as our second random number for site 1 in stratum 1
 

Example: (0.750) this will be used to determine our (x) coordinate;
- (h) Let the y coordinate of the area be the chainage or length of the stratum and let the x coordinate of the area be the width or offset from the left hand side;
- (i) The chainage for site one will be at (0.846 multiplied by the length of the stratum) = y (stratum 1)
 

Example:  $0.846 \times 125\text{m} = 105.8\text{m}$  (The Y Coordinate chainage should be rounded to 0.1m);
- (j) The offset from the left hand side for site one will be at (0.750 multiplied by the width of the stratum) = x (stratum 1).
 

Example:  $x = 0.750 \times 8\text{m} = 6.0\text{m}$  (The X Coordinate chainage should be rounded to 0.1m);
- (k) Select further random numbers by proceeding vertically down the column and if necessary to the top of the next column until as many numbers as required are obtained;

- (l) The chainage for site two will be at (0.317) multiplied by the length of the stratum) = y (site 2).

Example:  $y = 0.317 \times 125\text{m} = 39.6\text{m};$

- (m) The offset from the left hand side for site 2 will be (0.403) multiplied by the length of the stratum) = y (site 2).

Example:  $x = 0.403 \times 8\text{m} = 3.2\text{m offset};$

- (n) Add the lengths of all proceeding stratas to the y co-ordinate chainage to produce a running chainage.

Example: (39.6 + 125)  
Running chainage = 164.6m;

- (o) Project chainages may also be added if required.

Example: 164.6m or 0.1646km + (project chainage) = \_\_\_\_\_ kms  
0.1646km + 13.24km = 13.405kms.

### **NOTES ON TEST:**

1. Random sampling does not imply haphazard sampling but requires a detailed predetermined sampling plan which eliminates bias.
2. Random numbers may be selected by a variety of appropriate techniques. The method detailed here shall take precedence.
3. When selecting subsequent series of random numbers it is possible that the same series may occur more than once. When this is the outcome in successive lots, the second series of random numbers should be discarded and a further series of numbers selected.
4. When conducting retesting of a lot, a new series of random numbers shall be selected.
5. If in selecting a series of random numbers by running vertically down the column, the bottom right hand corner of the table is reached, continue selecting numbers from the top left hand corner of the page.
6. Retesting is only appropriate if there has been a mistake in sampling or test procedure or if the result is obviously impossible. If the volume of retesting is greater than one stratum, all testing for the lot shall be discarded and a new set of random numbers obtained and the entire lot retested.
7. Apart from retesting for the reason indicated in Note 6, there is no statistical justification for retesting a stratum or part of a lot which fails.

### **3. REPORT**

Report as per attached worksheet.

**'EXAMPLE ONLY'**

**SITE SELECTION BY THE STRATIFIED RANDOM TECHNIQUE**

**Worksheet**

**Project:** Feature: Fill/Subgrade etc  
**Location:**  
**Testing Agency:** Tested by:

1	Width m	8
2	Length m	1000
3	Area m <sup>2</sup>	8000
4	Number of Tests (Specification 1 per 1000m <sup>2</sup> )	8
5	Length of each strata m	125
6	Number the strata	1 to 8
7	Starting point (selected blindly)	0.271
8	Column number	2
9	Row number	71

**RANDOM NUMBERS AND LOCATIONS**

Strata No.	Random No.'s	Test Site Offset (x) multiplied by width of strata	Ch. for each strata (y) multiplied by length of strata	Running Ch. for each strata plus ongoing strata lengths	Project Ch. running Ch. plus datum.
		8m	125m	125,250 m etc	Datum km
1 (y)	0.846	-	105.8	105.8	
(x)	0.750	6.0	-	(-)	
2 (y)	0.317	-	39.6	164.6	
(x)	0.403	3.2	-	(+125m)	
3 (y)	0.527	-	65.9	315.9	
(x)	0.823	6.6	-	(+250m)	
4 (y)	0.939	-	117.4	492.4	
(x)	0.752	6.0	-	(+375m)	
5 (y)	0.337	-	42.1	542.1	
(x)	0.823	6.6	-	(+500m)	
6 (y)	0.789	-	98.6	723.6	
(x)	0.250	2.0	-	(+625m)	
7 (y)	0.313	-	39.1	789.1	
(x)	0.652	5.2	-	(+750m)	
8 (y)	0.480	-	60.0	935.0	
(x)	0.982	7.9	-	(+875m)	
9 (y)					
(x)					
10 (y)					
(x)					

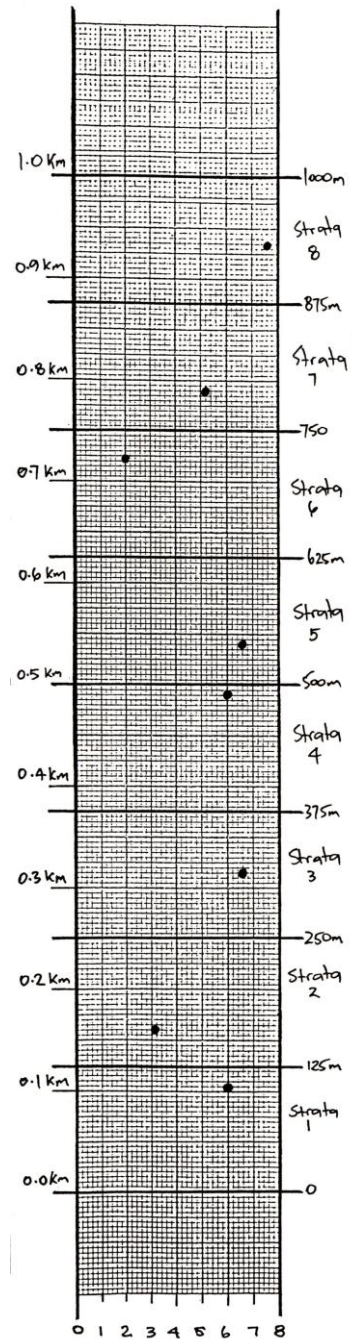

**SITE SELECTION BY THE STRATIFIED RANDOM TECHNIQUE**

**Worksheet**

**Project:** \_\_\_\_\_ **Feature: Fill/Subgrade etc**  
**Location:** \_\_\_\_\_  
**Testing Agency:** \_\_\_\_\_ **Tested by:** \_\_\_\_\_

1	Width m	
2	Length m	
3	Area m <sup>2</sup>	
4	Number of Tests	
5	Length of each strata m	
6	Number the strata	
7	Starting point (selected blindly)	
8	Column number	
9	Row number	

**RANDOM NUMBERS AND LOCATIONS**

Strata No.	Random No.'s	Test Site Offset (x) multiplied by width of strata  .....m	Ch. for each strata (y) multiplied by length of strata  .....m	Running Ch. for each strata plus ongoing strata lengths  .....m	Project Ch. running Ch. plus datum.  Datum km
1 (y) (x)					
2 (y) (x)					
3 (y) (x)					
4 (y) (x)					
5 (y) (x)					
6 (y) (x)					
7 (y) (x)					
8 (y) (x)					
9 (y) (x)					
10 (y) (x)					

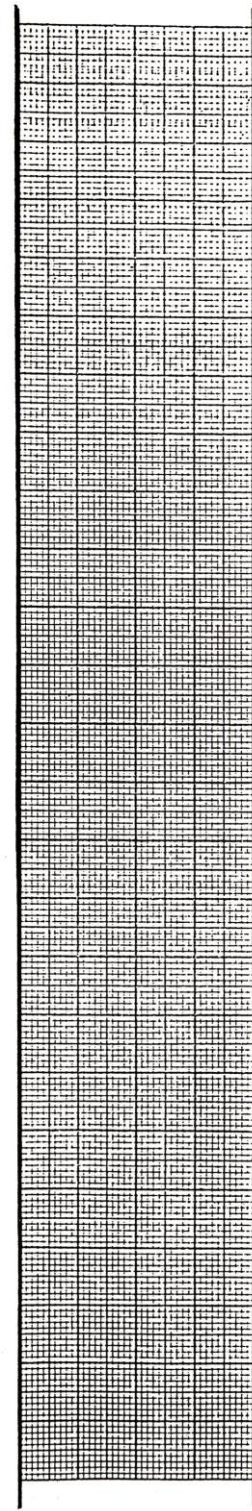



**RANDOM NUMBER TABLE**

	0	1	2	3	4	5	6	7	8	9
0	0.092	0.734	0.817	0.945	0.406	0.535	0.447	0.541	0.990	0.424
1	0.821	0.096	0.524	0.619	0.121	0.225	0.974	0.939	0.802	0.840
2	0.637	0.840	0.584	0.609	0.783	0.801	0.391	0.965	0.988	0.303
3	0.108	0.592	0.764	0.089	0.472	0.895	0.556	0.941	0.961	0.394
4	0.726	0.694	0.011	0.528	0.600	0.693	0.418	0.832	0.175	0.431
5	0.252	0.951	0.583	0.565	0.146	0.472	0.912	0.044	0.290	0.030
6	0.457	0.565	0.971	0.660	0.021	0.071	0.024	0.875	0.336	0.511
7	0.009	0.418	0.218	0.590	0.479	0.180	0.536	0.712	0.179	0.228
8	0.589	0.845	0.507	0.438	0.997	0.530	0.095	0.680	0.687	0.738
9	0.856	0.031	0.071	0.813	0.319	0.999	0.017	0.201	0.626	0.194
10	0.694	0.200	0.005	0.452	0.894	0.441	0.090	0.853	0.927	0.312
11	0.907	0.620	0.668	0.064	0.892	0.346	0.873	0.801	0.767	0.553
12	0.332	0.070	0.625	0.007	0.974	0.291	0.075	0.798	0.503	0.721
13	0.775	0.632	0.673	0.186	0.209	0.300	0.777	0.293	0.050	0.820
14	0.463	0.348	0.945	0.179	0.458	0.689	0.077	0.189	0.301	0.662
15	0.341	0.383	0.668	0.946	0.476	0.462	0.402	0.466	0.004	0.216
16	0.820	0.594	0.311	0.436	0.407	0.861	0.723	0.740	0.481	0.911
17	0.912	0.819	0.928	0.894	0.481	0.050	0.599	0.041	0.074	0.947
18	0.462	0.617	0.843	0.430	0.106	0.990	0.634	0.370	0.686	0.020
19	0.718	0.380	0.904	0.497	0.420	0.323	0.126	0.840	0.493	0.514
20	0.218	0.780	0.570	0.060	0.200	0.244	0.548	0.342	0.322	0.158
21	0.238	0.072	0.632	0.389	0.140	0.922	0.654	0.547	0.665	0.176
22	0.251	0.855	0.669	0.384	0.286	0.829	0.628	0.479	0.154	0.953
23	0.308	0.335	0.789	0.102	0.264	0.220	0.251	0.908	0.020	0.136
24	0.456	0.797	0.271	0.484	0.183	0.919	0.945	0.055	0.911	0.677
25	0.481	0.790	0.616	0.093	0.156	0.292	0.090	0.707	0.808	0.557
26	0.906	0.252	0.802	0.884	0.594	0.799	0.577	0.446	0.145	0.617
27	0.619	0.480	0.421	0.436	0.215	0.572	0.577	0.367	0.811	0.996
28	0.073	0.164	0.335	0.593	0.391	0.073	0.319	0.139	0.032	0.967
29	0.176	0.681	0.893	0.005	0.453	0.812	0.622	0.512	0.434	0.352
30	0.041	0.319	0.906	0.392	0.231	0.268	0.458	0.191	0.371	0.110
31	0.139	0.879	0.926	0.505	0.826	0.435	0.284	0.352	0.144	0.925
32	0.425	0.163	0.290	0.441	0.720	0.701	0.582	0.738	0.458	0.600
33	0.107	0.022	0.193	0.183	0.289	0.858	0.495	0.209	0.732	0.670
34	0.217	0.748	0.172	0.807	0.852	0.921	0.896	0.634	0.094	0.709
35	0.461	0.621	0.173	0.569	0.054	0.898	0.084	0.047	0.352	0.249
36	0.281	0.139	0.209	0.009	0.946	0.595	0.019	0.832	0.414	0.890
37	0.110	0.801	0.859	0.096	0.995	0.853	0.828	0.347	0.831	0.977
38	0.713	0.140	0.940	0.167	0.775	0.176	0.715	0.581	0.777	0.968
39	0.774	0.902	0.863	0.928	0.698	0.334	0.741	0.159	0.190	0.238
40	0.784	0.663	0.013	0.848	0.137	0.188	0.540	0.056	0.421	0.440
41	0.262	0.719	0.130	0.858	0.099	0.469	0.323	0.695	0.862	0.489
42	0.685	0.608	0.698	0.221	0.570	0.482	0.875	0.487	0.112	0.701
43	0.740	0.968	0.995	0.597	0.202	0.544	0.983	0.279	0.581	0.427
44	0.794	0.575	0.160	0.585	0.424	0.297	0.298	0.405	0.504	0.555
45	0.432	0.087	0.787	0.330	0.822	0.702	0.362	0.034	0.386	0.426
46	0.686	0.263	0.451	0.885	0.029	0.483	0.784	0.090	0.422	0.841
47	0.735	0.945	0.705	0.845	0.844	0.767	0.771	0.109	0.741	0.821
48	0.598	0.905	0.700	0.310	0.156	0.717	0.685	0.805	0.791	0.537
49	0.221	0.579	0.185	0.106	0.949	0.816	0.464	0.827	0.208	0.155
50	0.575	0.565	0.465	0.555	0.503	0.062	0.974	0.928	0.439	0.165
51	0.475	0.530	0.479	0.611	0.291	0.564	0.958	0.569	0.670	0.963
52	0.007	0.664	0.710	0.843	0.424	0.711	0.704	0.561	0.470	0.855
53	0.268	0.878	0.655	0.361	0.075	0.174	0.133	0.758	0.555	0.198
54	0.789	0.555	0.391	0.316	0.614	0.260	0.168	0.720	0.455	0.904
55	0.006	0.576	0.748	0.804	0.532	0.582	0.312	0.776	0.029	0.888
56	0.812	0.513	0.102	0.865	0.969	0.358	0.715	0.686	0.132	0.182
57	0.935	0.177	0.278	0.587	0.226	0.930	0.064	0.156	0.641	0.120
58	0.000	0.961	0.762	0.013	0.350	0.067	0.706	0.630	0.852	0.219
59	0.080	0.532	0.847	0.464	0.191	0.193	0.920	0.903	0.378	0.944
60	0.632	0.303	0.807	0.933	0.455	0.789	0.556	0.093	0.485	0.321
61	0.364	0.575	0.042	0.197	0.853	0.611	0.742	0.280	0.596	0.290
62	0.140	0.177	0.859	0.198	0.528	0.091	0.359	0.407	0.001	0.562
63	0.901	0.771	0.359	0.808	0.206	0.002	0.964	0.905	0.807	0.493
64	0.125	0.498	0.333	0.363	0.122	0.288	0.039	0.677	0.446	0.991
65	0.911	0.333	0.366	0.005	0.209	0.560	0.400	0.496	0.777	0.520
66	0.801	0.120	0.963	0.957	0.631	0.103	0.511	0.390	0.541	0.900
67	0.242	0.790	0.827	0.148	0.889	0.233	0.875	0.127	0.921	0.486
68	0.577	0.464	0.701	0.998	0.814	0.277	0.820	0.260	0.603	0.498
69	0.955	0.013	0.002	0.581	0.090	0.262	0.361	0.313	0.447	0.572
70	0.017	0.959	0.974	0.609	0.027	0.450	0.716	0.400	0.032	0.828
71	0.946	0.282	0.846	0.683	0.362	0.995	0.862	0.785	0.223	0.909
72	0.870	0.637	0.750	0.839	0.382	0.167	0.648	0.415	0.057	0.280
73	0.081	0.491	0.317	0.483	0.954	0.546	0.755	0.302	0.842	0.551
74	0.414	0.722	0.403	0.277	0.556	0.353	0.633	0.501	0.981	0.542
75	0.794	0.088	0.527	0.169	0.363	0.416	0.809	0.320	0.850	0.111
76	0.817	0.569	0.823	0.558	0.460	0.092	0.982	0.165	0.634	0.321
77	0.640	0.839	0.939	0.361	0.426	0.654	0.603	0.893	0.597	0.162
78	0.737	0.777	0.752	0.343	0.496	0.072	0.336	0.633	0.247	0.699
79	0.751	0.017	0.337	0.459	0.427	0.654	0.556	0.627	0.699	0.999
80	0.883	0.843	0.823	0.888	0.617	0.512	0.993	0.561	0.480	0.445
81	0.680	0.093	0.789	0.939	0.161	0.194	0.291	0.039	0.557	0.848
82	0.754	0.182	0.250	0.767	0.904	0.950	0.993	0.129	0.813	0.146
83	0.589	0.551	0.313	0.922	0.453	0.787	0.553	0.165	0.923	0.118
84	0.270	0.867	0.652	0.879	0.888	0.696	0.927	0.126	0.020	0.486
85	0.259	0.885	0.480	0.869	0.090	0.966	0.400	0.761	0.963	0.801
86	0.529	0.925	0.982	0.289	0.329	0.332	0.932	0.099	0.944	0.526
87	0.883	0.413	0.653	0.738	0.628	0.571	0.882	0.934	0.801	0.594
88	0.384	0.544	0.014	0.041	0.671	0.073	0.859	0.184	0.300	0.329
89	0.122	0.956	0.099	0.462	0.049	0.654	0.929	0.564	0.006	0.852
90	0.082	0.021	0.380	0.501	0.900	0.355	0.065	0.691	0.711	0.760
91	0.379	0.021	0.680	0.065	0.743	0.078	0.666	0.332	0.985	0.962
92	0.674	0.810	0.600	0.350	0.008	0.470	0.808	0.054	0.706	0.829
93	0.767	0.543	0.353	0.294	0.767	0.409	0.878	0.732	0.765	0.228
94	0.409	0.496	0.097	0.800	0.797	0.619	0.707	0.228	0.895	0.397
95	0.744	0.810	0.183	0.079	0.870	0.208	0.838	0.882	0.119	0.865
96	0.846	0.057	0.649	0.140	0.236	0.207	0.239	0.130	0.046	0.603
97	0.873	0.642	0.103	0.685	0.239	0.291	0.218	0.495	0.513	0.193
98	0.887	0.242	0.253	0.207	0.085	0.729	0.750	0.222	0.264	0.851
99	0.685	0.432	0.130	0.895	0.429	0.077	0.304	0.844	0.838	0.626

## JOINT AUDIT TESTING OF COMPACTION

### 1. SCOPE

This Code sets out the procedure which shall be followed when the Superintendent, as a result of a dispute, elects to invite both parties jointly to audit a lot.

### 2. PURPOSE

To determine the conformance status of a lot, irrespective of all previous tests and audits.

### 3. PREPARATION

- (a) Jointly select and agree on a time to conduct the joint audit;
- (b) Jointly agree on the most appropriate facility, equipment and nuclear densometer to conduct the joint-audit;
- (c) Testing personnel from both parties shall be present during all phases of sampling and testing;
- (d) The execution of all testing tasks shall be divided approximately equal between both parties.

### 4. METHOD

- (e) Jointly determine the location of the tests using a stratified random technique in accordance with NTCP 103.1.;
- (f) Jointly check the nuclear densometer calibration status, gauge function checks and secondary calibration;
- (g) Jointly determine the standard counts on site in accordance with the manufacturer's handbook and AS1289 5.8.1.;
- (h) Jointly conduct the density testing in accordance with Department of Infrastructure and Australian Standard requirements;
- (i) From each site take samples for moisture content, and modified compaction determinations;
- (j) At the completion of all field testing both parties shall return to the nominated facility to jointly process the samples and test results and reports in accordance with Australian Standard AS1289;
- (k) Calculations shall be to the satisfaction of both parties;
- (l) The results of these joint tests shall be used to determine the conformance status of the lot in accordance with the specification requirements;
- (m) At any time, and upon the request of either party the Superintendent and Contractor shall carry out an evaluation of their respective testing methods to determine the reason for any continuing discrepancies and arrive at a uniform testing technique.

**NOTES ON TEST:**

1. Determine the moisture content in accordance with AS1289.2.1.1.;
2. Excavate the sample for the moisture content determination between the source rod and the detector and to the depth of the source rod and ensure the sides of the hole are reasonably vertical;
3. Ensure the sample for the modified compaction determination is taken beneath the gauge to the depth of the source rod and ensure the sides of the hole are vertical;
4. Jointly record all readings and cross check recordings;
5. At the completion of field testing both parties shall initial all recordings;
6. Moisture content samples will be placed in the oven overnight;
7. Both parties shall have the option to keep a copy of the recordings overnight;
8. No one party shall proceed with the samples in the absence of the other party.

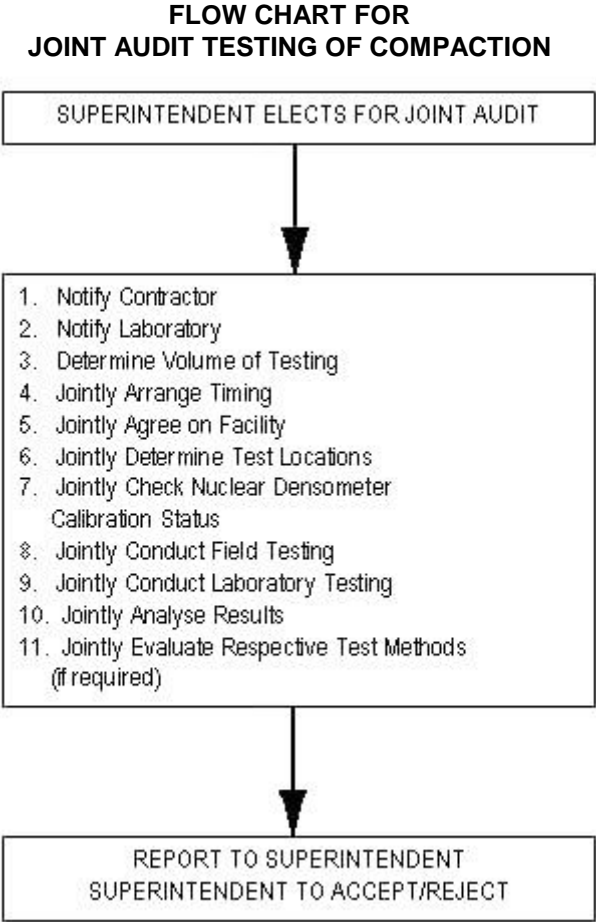

## REGISTRATION OF ASPHALT MIX DESIGNS

### 1. INTRODUCTION

This Code of Practice describes the process for registration of asphalt mix designs for use in works undertaken for the Department of Infrastructure (DoI).

Registration in accordance with the procedures in this Code of Practice does not guarantee the handling and performance properties of this mix. Production, delivery, placement and compaction of asphalt mixes shall comply with the relevant sections of the DoI Road works Master Specification and any specific project requirements.

### 2. REGISTRATION

#### 2.1 General

Applications to register an asphalt mix shall be submitted to The Department at least two weeks prior to the proposed date of commencement of supply and shall be accompanied by the information listed in Clause 2.2.

The registration of a mix design shall remain current for a period of 2 years subject to there being no changes to the source or grading of aggregate components or the source and nature of the binder. Registration may be extended beyond 2 years with the agreement of the Department and the Superintendent of the project on which the mix is to be used.

#### 2.2 Information Required

The following information shall be submitted for each new mix design:

- a) Grading test results for each component;
- b) Proportion of each component in the mix;
- c) Grading of the mix;
- d) Graphs of mix properties;
- e) Supplier and class of binder and certificate of compliance;
- f) Source of added filler and certificate of compliance for added filler;
- g) Details of the type of additives, if any, and its proportion in the design mix;
- h) Details of any proposed asphalt recycling including sieve analysis (after extraction of binder) and binder content of RAP;
- i) Test information for all laboratory tests for the relevant mix type specified in Section 3;
- j) Test information from production trial and modification of laboratory test data for identification as the "Job Mix";
- k) All the test results shall be current at the time of submission of the mix design;
- l) All components of the asphalt mix shall comply with the DoI Road works Master Specification Section 9 – Dense Graded Asphalt.

#### 2.3 Additional information required for Warm Mix Asphalt (WMA) Registration

- a) WMA technology and/or WMA additives information including the classification and nominated proportions of additives;
- b) WMA technology manufacturer's established target rate for water and additives and the acceptable variation for production;
- c) Documentation that demonstrates proven field performance of the WMA technology for at least 2 years. Trials undertaken through Austroads and other State Authorities will be accepted.

## 2.4 Notifications of Approval

Acceptance or rejection of applications for registration of asphalt mixes will be advised in writing. Additional information may be required by the department to complete the registration process.

Approved mixes will be issued with an identifying code.

Sufficient quantities of all components shall be provided for independent verification and assessment of the submitted mix design on request by the Department.

## 3. MIX DESIGN REQUIREMENTS

### 3.1 General

Mix design procedures and test methods shall follow the guidelines provided in Austroads Guide to Pavement Technology Part 4B – Asphalt. Volumetric properties (Level 1 design) may be determined using either Gyrotory compaction (AS 2891.2.2) or Marshall compaction (AS 2891.5) of laboratory prepared or plant mixed specimens.

All testing shall be undertaken in a laboratory accredited by NATA for the relevant test methods.

**Table 1 - Traffic category and binder requirements for dense graded asphalt mix types**

Traffic Category	Application	Bitumen Type
Light	Cycle Paths	Class 320 or S10E
Medium	Car Parks and Low Volume Traffic – less than 300 vld	Class 320 or S10E
Heavy	All Urban Roads and Intersections	A15E

*vld = vehicles per lane per day*

### 3.2 Grading and binder content

The proportions of aggregate and binder in the mix and grading of aggregates including any added filler, after mixing but before compaction, shall lie within the limits specified in Tables 3 and 4 for each size of and type of asphalt unless otherwise approved by the DoI.

**Table 3 - Grading**

Mix Type	1	2	3	4	5	6
Mix Size (mm)	7	10	14	20	14 (A15E)	10 mm (Car Park)
Sieve Size AS (mm)	Percentage passing sieve size (by mass)					
26.5				100		
19.0			100	95–100	100	
13.2		100	85–100	75–90	85 – 100	100
9.5	100	90–100	70–85	60–80	70 – 85	90–100
6.7	85–100	70–90	62–75	50–70	62 – 75	68–87
4.75	70–87	58–76	53–70	40–60	53 – 70	50–76
2.36	44–65	40–58	35–52	25–43	35 – 52	32–57
1.18	29–48	27–44	24–40	18–35	24 – 40	22–42
0.60	19–35	17–35	15–30	14–27	15 – 30	15–31
0.30	12–25	11–24	10–24	9–21	10 – 24	10–23
0.15	8–16	7–16	7–16	6–15	7 – 16	6–14
0.075	5–8	4–7	4–7	3–7	4– 7	4–7
Total	100	100	100	100	100	100

The grading curve shall be smooth and shall not vary from the outer one third of the range between the specified limits for one sieve size to the opposite outer one third of the range between the specified limits for an adjacent sieve size.

**Table 4 - Binder content**

Mix Type	1	2	3	4	5	6
Mix Size (mm)	7	10	14	20	14 (A15E)	10 mm (Car Park)
Binder Content (%by mass)	5.0 – 7.0	4.5 – 6.5	4.6 – 6.5	4.0 - 6.0	4.8 – 6.5	4.5 – 6.5

### 3.3 Binder Film Index

Binder film index of all mix types shall be a minimum of 8.0 micron.

### 3.4 Volumetric test properties

#### a) *Gyratory compaction*

Mixes designed using gyratory compaction shall comply with the requirements of Table 5.

**Table 5 - Compaction cycles and air voids for volumetric properties determined by gyratory compaction**

Mix Type	1	2	3	4	5	6
Mix Size (mm)	7	10	14	20	14 (A15E)	10 mm (Car Park)
Compaction cycles	Design air voids in laboratory compacted mix (%)					
50	4.0	N/A	N/A	N/A	N/A	4.0
80		4.0	N/A	N/A	N/A	N/A
120		4.0	4.0	4.0	4.0	N/A
250	N/A	>2.5	>2.5	>2.5	>2.5	N/A

Notes to Table 5

The design air voids values are approximate and may be adjusted to account for rounding of the binder content value to the nearest 1.0%.

#### b) *Marshall compaction*

Mixes designed using Marshall compaction (50 blows) shall comply with the requirements of Table 6.

**Table 6 - Marshall Properties and air voids for mixes designed using Marshall Compaction**

Mix Type	1	2	3	4	5	6
Size (mm)	7	10	14	20	14 (A15E)	10
Design air voids	4.0	5.0	5.0	5.0	5.0	4.0
Stability (min) (kN)	6.5	10	10	10	15	10
Flow (mm)	2-4	2-4	2-4	2-4	2-4	2-4

Notes to Table 5

The design air voids values are approximate and may be adjusted to account for rounding of the binder content value to the nearest 1.0%.

### 3.5 Wheel Track Test Requirements

The maximum Tracking Depth tested under the Austroads Wheel tracking test method shall not exceed the values for asphalt mixes specified in Table 7.

**Table 7 - Maximum wheel tracking depth**

Mix Type	1	2	3	4	5	6
Size (mm)	7	10	14	20	14 (A15E)	10
Traffic category	Maximum tracking depth at 60°C (mm)					
Light traffic	N/A	N/A	N/A	N/A	N/A	N/A
Medium traffic	N/A	N/A	N/A	N/A	N/A	N/A
Heavy traffic	N/A	3-6	3-6	3-6	1-3	N/A

Notes to Table 6

Wheel tracking test specimens shall be compacted to 5% air voids within a tolerance of 1% air voids. Total rut depth is determined after 10,000 cycles.

### 3.6 Asphalt Mixes Containing Reclaimed Asphalt Pavement

Up to 15% of RAP may be incorporated in the design of Type 4 mixes subject to meeting the design requirements as described Section 3.

## 4. PRODUCTION TRIAL AND JOB MIX DESIGN

A production trial shall be undertaken on the laboratory design mix to determine the Job Mix Design.

The production trial shall be used to verify the proportion of components, binder content, grading and Marshall Properties of the asphalt mix meeting the mix design requirements specified in Section 3 and conforming with the tolerance on finished asphalt properties specified in the DoI Road works Master Specification. Adjustments to the blend composition as a result of production trial shall be designated the Job Mix Design.

## RIDE QUALITY

### 1. INTRODUCTION

This Code of Practice provides guidelines for the testing and acceptance of ride quality on asphalt works undertaken for the Department of Infrastructure (DoI).

### 2. DEFINITIONS

#### 2.1 Continuous Traffic Lane

A length of traffic lane which can be tested in a single test run uninterrupted by areas exempted from ride quality assessment.

#### 2.2 International Roughness Index (IRI<sub>qc</sub>)

The international measure of ride quality measured and recorded by in cumulative metres per kilometre in each wheel path and averaged together. For the purposes of this Code of Practice, roughness measurement is to be based on the IRI<sub>qc</sub> quarter car model.

Where required to convert between IRI and NAASRA counts/km, one NAASRA count in counts/km/lane is approximately equivalent to an IRI of 0.04 m/km/lane. The more precise conversion is given by the following formulae:

$$\text{NAASRA Counts/km/lane} = (26.49 \times \text{IRI}) - 1.27$$

or

$$\text{IRI (m/km/lane)} = (\text{NAASRA Counts/km/lane} + 1.27) / 26.49$$

#### 2.3 Mean Lane Roughness Value

The mean of the Individual Lane Roughness Values within the lot as determined by the appropriate test method.

#### 2.4 Measuring Device

The device used for measurement of roughness shall be:

- (a) Normal testing by DoI Rough-o-meter, calibrated to provide roughness counts converted to IRI.
- (b) In the event of non-compliance, The Contractor shall have the option of requesting retest by ARRB Profile-o-meter. The cost of retesting will be allocated to the Contractor unless the retesting shows compliance with the specified requirements, in which case the cost of retesting will be paid by the Department.

### 3. LOT TESTING

All work shall be tested in lots of continuous traffic lane. A lot shall be defined as the length and width of each continuous traffic lane constructed including any freeway ramps but excluding shoulders and turn lanes. The maximum length of the lot shall be restricted to 2 km of continuous traffic lane.

The minimum length of the lot shall be the lesser of the total job length or 500 m.

Start and finish joints are to be excluded from testing.

Following areas may be excluded from ride quality testing or specified at a lower standard of ride quality unless otherwise specified.

- Bridge decks, depending on the type of construction and number and type of expansion joints.
- Small jobs (less than 300m in length) areas of limited access, roundabouts other very low speed traffic locations.
- Left lanes used as parking for most of the day or where the crown of an intersecting road intrudes into the left lane.



- Pavement widening and part width reconstruction where the completed works is required to match the profile of the adjacent existing pavement or required to match the ride quality of the existing pavement.

Ride quality measurement shall be undertaken within three months after the application of the surfacing.

#### 4. **RECTIFICATION**

Where the Mean Lane Roughness Value of a lot is greater than the Mean Lane Roughness specified, the work shall be rectified unless the Superintendent agrees to accept the work at a reduced payment. Where the lot is to be rectified, the minimum length for any rectification work undertaken shall be 100 m. Where the Superintendent agrees to accept the lot at a reduced payment, a deduction to the contract sum shall be made in accordance with the provisions for MEASUREMENT AND PAYMENT.

The Contractor shall bear the full cost of any necessary rectification work including the cost of any additional work required to the underlying or adjacent pavement to comply with the ride quality requirements of the specification. All rectification work shall be carried out in accordance with the requirements of the specification.

A re-test of the lot shall be undertaken following completion of any rectification work.

## INDEX OF TEST METHODS

TEST METHOD	SECTION 2 - SAMPLING & TESTING SOILS	PAGE NUMBER
NTTM 201.2	Modified Compaction – Lime Stabilised Materials	2
NTTM 201.3	Modified Compaction – Cement Stabilised Materials	5
NTTM 201.4	Modified Compaction – Bituminous Stabilised Materials	7
NTTM 202.2	California Bearing Ratio – Lime Stabilised Materials	10
NTTM 202.3	California Bearing Ratio – Cement Stabilised Materials	13
NTTM 203.1	Unconfined Compressive Strength	15
NTTM 204.1	Cement Content of Stabilised Materials – Heat of Neutralisation	21
NTTM 204.5	Determination of the Lime Saturation Point of Stabilised Materials – Ph Method	24
NTTM 204.6	Available Calcium Oxide or Calcium Hydroxide in Lime	27
NTTM 204.7	Rate of Spread of Lime or Cement	30
NTTM 204.8	Stabiliser Distribution	31
NTTM 205.1	Durability Cement Stabilised Materials	32
NTTM 211.1	Plate Bearing Test	36
NTTM 215.1	Standard Ball Penetration Test	39
NTTM 216.1	Measurement of Layer Thickness	41
NTTM 217.1	Particle Size Distribution – Oversize Material	43

## MODIFIED COMPACTION - LIME STABILISED MATERIALS

### 1. SCOPE

This test method sets out the procedures for determination of the relationship between Dry Density and Moisture Content for mixtures of Materials and Lime stabilised in the field, or materials stabilised in the laboratory.

This method is applicable to materials having no more than 20% retained on the 37.5mm AS sieve.

### 2. APPARATUS

As described in Australian Standard AS1289.5.2.1.

### 3. PREPARATION OF SAMPLE

Prepare the sample in accordance with the procedure prescribed in AS1289.2.1.1, AS1289.5.2.1 and AS1289.5.4.1.

### 4. PROCEDURE

#### 4.1 Stabilised in the Field

- (a) The sample shall be taken within one hour from the time from the completion of mixing in-situ;
- (b) Immediately after the sample has been taken it shall be sealed in an airtight container, sheltered, and transported as soon as practicable to the laboratory for processing;
- (c) The procedure is to be commenced immediately the sample is removed from the airtight container;
- (d) Prepare the specimen in accordance with AS1289.5.2.1 and AS1289.5.4.1;
- (e) Cure the sample overnight;
- (f) Compact the sample in accordance with AS1289.5.2.1;
- (g) The compaction of the specimen is to be completed within 48 hours of delivery for plant mixed material or, in the case of in-situ work, within 48 hours of the completion of mixing.

#### 4.2 Stabilised in the Laboratory

- (a) Follow AS1289.5.2.1 Procedure (a) to (d) inclusive;
- (b) Take one of the portions and determine the mass to the nearest 1g. Screen on a 4.75mm sieve. All material retained on the 4.75mm AS sieve shall be soaked for at least one hour and then surface dried;
- (c) Incorporate the prescribed additive as follows:
  - i. Hydrated Lime: Add the required amount of hydrated lime, calculated as a percentage of the total dry mass of the portion as determined in 4(b) to the material passing the 4.75mm AS sieve and thoroughly mix the dry materials to a uniform colour.

- ii. Quicklime: Add the required amount of ground quicklime, calculated as a percentage of the total dry mass of the portion determined in 4(b), to the material passing the 4.75mm AS sieve and thoroughly and carefully mix the dry materials to a uniform colour. Add a quantity of water equal to one-half to two-thirds of the mass of quicklime added to the material. Carefully mix, observing the safety precautions set out in Note 5. Slaking will occur rapidly with the generation of heat. The magnitude of the reaction will depend on the amount of quicklime present. Cover the mixture and allow to stand for about 10 minutes. Remix to break up any lumps that may have formed.

**See Note 5 for safety precautions related to the use of quicklime.**

- (d) Add the required quantity of water to the mix. Select the quantities of water to be added so that the soil optimum moisture content is straddled and the moisture steps are not excessive for the soil type.
- (e) Incorporate the saturated surface dry material retained on the 4.75mm sieve and remix.
- (f) Repeat this procedure with the remaining portions of material.
- (g) Place the mixture in a container and seal. Allow the mixture to cure overnight at room temperature.
- (h) Remix the material and adjust moisture if necessary.
- (i) Compact the material in accordance with AS1289.5.2.1, procedure (g) to (q) inclusive.

## 5. CALCULATIONS

In accordance with AS1289.5.2.1 and AS1289.5.4.1.

## 6. REPORTING

In accordance with AS1289.5.2.1 and AS1289.5.4.1.

### **NOTES ON TEST:**

1. Lime used in laboratory investigations should be the same type from the same source of supply or manufacture as the lime proposed for use in the field. Unless otherwise specified or approved, quicklime and hydrated lime shall comply with Australian Standard 1672.1 – Limes and Limestone – Limes for Building.
2. Hydrated lime is the most common form of lime used in lime stabilisation of road materials. It is usually supplied in the form of a fine, white powder and consists essentially of calcium hydroxide. No preparation is required.
3. Quicklime is supplied as ground quicklime, crushed or pebble quicklime or as lumps, and consists essentially of calcium oxide. Unless supplied in ground form, the material should be ground to pass a 2.36mm AS sieve and stored in an air-tight container and protected from moisture until used.
4. Hydrated lime is relatively safe but care is required to protect the eyes when using hydrated lime.

5. **Quicklime may be dangerous in the presence of moisture because of its highly caustic nature. Even small amounts of perspiration on the skin may react with quicklime and cause skin burns. Quicklime is especially dangerous to the eyes. Safety glasses, long-sleeved coats and gloves should be worn, and protective cream applied to the hands and arms as required, when using quicklime in the laboratory.**

## MODIFIED COMPACTION - BITUMEN STABILISED MATERIALS

### 1. SCOPE

This test method sets out the procedures for the determination of the relationship between dry density and moisture content for mixtures of soil, gravel or crushed rock material and bitumen, cut-back bitumen, bitumen emulsion, or tar.

This method is applicable to materials with not more than 20% retained on the 37.5mm A.S. Sieve.

### 2. APPARATUS

As described as AS1289.5.2.1

### 3. PREPARATION OF SAMPLE

- (a) Allow the sample to dry sufficiently to enable it to be crumbled. If necessary, dry the sample at a temperature not exceeding 50°C;
- (b) Break up any aggregations of particles in such a way as to avoid crushing any discrete particles. All aggregations of particles are to be broken down so that if the sample was screened on a 4.75mm A.S. sieve only discrete uncrushed particles would be retained. A rubber pestle should be used to avoid breaking down sound pieces of mineral matter. Adhering material should be brushed from coarse pieces. When in doubt as to whether lumps are to be broken, place some in water and boil. If slaking occurs, the material should be broken further with the rubber pestle;
- (c) Prepare the sample and select the mould size in accordance with AS 1289.5.2.1 and AS 1289.5.4.1;
- (d) Obtain by quartering or riffing six 3000g portions of the prepared sample.

### 4. BITUMINOUS MATERIALS

- (a) Bituminous materials used in laboratory investigations should be of the same type and from the same source of supply or manufacture as the materials proposed for use in the field. Unless otherwise specified or approved the bituminous materials should comply with the requirements of the appropriate Australian Standard (i.e. Bitumen, Cut Back Bitumen, Bitumen Emulsion, or Tar);
- (b) Where bitumen emulsion is specified or approved for use in investigations in relation to stabilisation or modification of road materials, the water used in the test should be from the same source as that proposed for use in the field.

### 5. ADDITION OF THE BITUMINOUS MATERIAL

#### ( i ) DETERMINATION OF THE DESIRABLE VISCOSITY AND MOISTURE CONTENT FOR THE ADDITION OF BITUMEN OR CUT BACK BITUMEN

- (a) Take one of the 3000g portions of the sample obtained in 3 (d) and quarter or riffle it to obtain 6 to 8 portions, each about 300g;

- (b) Take one of the 300g portions of soil, add sufficient water to dampen the soil, mix thoroughly and add a small quantity of bitumen that has been heated as necessary to produce a "pourable" condition. Mix with a trowel in an attempt to produce a uniform mix. If the viscosity is unsuitable for mixing, balls of unmixed bitumen will form. When this happens it is necessary to cut back the bitumen with power kerosene starting from 5 per cent cutter and increasing by 2 per cent increments;
- (c) To another 300g portion add a measured quantity of water (but do not exceed optimum moisture content at this stage) and add a small amount of cut-back bitumen. Mix thoroughly with a trowel and note ease (or difficulty) of mixing;
- (d) Repeat procedures (b) and (c) with increases in moisture content of the soil and/or the proportion of cutter in the bitumen until conditions for satisfactory mixing are determined;
- (e) Record the moisture content of the soil and the cutter content of the bitumen at which satisfactory mixing occurred;
- (f) Adopt the soil moisture content and cutter content of the bitumen recorded in (e) in the mixtures to be tested in accordance with this Test Method;
- (g) Add the cut back bitumen to the moist soil in small quantities, mixing thoroughly after each addition, until the required amount of bitumen has been added to the soil.

**( ii ) DETERMINATION OF THE DESIRABLE VISCOSITY AND MOISTURE CONTENT FOR THE ADDITION OF TAR**

- (a) Adopt a similar procedure to that described for bitumen above except that, instead of fluxing with kerosene, different grades of tar should be used;
- (b) Add the desired grade of tar to the moist soil in small quantities, mixing thoroughly after each addition until the required amount of tar has been incorporated in the soil.

**( iii ) ADDITION OF BITUMEN EMULSION**

- (a) Dampen the test portion to a moisture content of approximately 4% to 5%;
- (b) Calculate the additional quantity of water to be added to bring the emulsion/soil mix to the desired moisture content. For this purpose the water content of bitumen emulsion shall be taken as 45 per cent by mass;
- (c) Dilute the bitumen emulsion by adding at least half the additional water to the bitumen emulsion. Add the remainder of the additional water to the soil portion;
- (d) Add the diluted bitumen emulsion to the soil portion in small quantities mixing thoroughly after each addition until the required amount of bitumen emulsion has been incorporated in the soil.

**6. PROCEDURE**

- (a) Take one of the portions and determine the mass to the nearest 1g. Screen on a 4.75 mm A.S. sieve. All material retained on the 4.75mm A.S. sieve shall be soaked for at least one hour and then surface dried;
- (b) Bring the soil to the moisture content and add the bituminous material as described in Section 5;
- (c) Compact the mixture into the mould in accordance with AS 1289.5.2.1;

- (d) Repeat processes (a) to (c) with the other portion adding the same amount of binder each time but increasing the quantity of water for each successive portion to provide the following approximate ranges:
- (i) Sandy Materials: 7 to 15 percent in steps of 2 percent;
  - (ii) Clayey Materials: 12 to 24 percent in steps of 4 percent.
- (e) Repeat the procedure for each of the specified additive contents.

## 7. CALCULATIONS

Perform calculations in accordance with AS1289.5.2.1.

## 8. REPORTING

Report the following results for each bitumen content as appropriate:

- (a) Type and source of bituminous material;
- (b) Additive content;
- (c) Amount of cutter used (if any) and moisture content at which binder was added;
- (d) Source of water if bitumen emulsion is used;
- (e) Maximum Dry Density in  $t/m^3$  to the nearest 0.01  $t/m^3$ ;
- (f) Optimum moisture content to the nearest 0.5%.

## 9. TECHNIQUES

- (a) The range of moisture contents required will vary according to the type of material to which the binder has been added. As a guide, the Plastic Limit gives an indication of the approximate upper limit of the range. In some cases it may be advisable to use increments of 2 per cent or less;
- (b) If difficulty is experienced in incorporating bitumen emulsion into the soil, an additive compatible with emulsion may be required.

eg. Anionic emulsions **must** be diluted with water of an alkaline nature. This may be achieved by the addition of 0.05 - 0.10% household detergent or phosphate softener (Calgon or equivalent) to the water before mixing with the emulsion.

Cationic emulsions **must** be diluted with water of an acidic nature. This may be achieved by the addition of 1% solution of hydrochloric acid (muriatic acid) or 0.05% by weight of amine salt, in a minimal amount just sufficient to acidify the local water.

If such an additive is found necessary, the type and quantity used should be recorded in the test report;

- (c) Difficulties may be experienced in the use of cut-back bitumen when mixed with road materials because of the slow rate of evaporation of cutter oil. The amount of cutter added should therefore be kept to a minimum.



## CALIFORNIA BEARING RATIO - LIME STABILISED MATERIALS

### 1. SCOPE

This test method sets out the procedure for the determination of the California Bearing Ratio for mixtures of materials modified or stabilised with lime, in the field or in the laboratory.

### 2. APPARATUS

As described in Australian Standard AS 1289.6.1.1

### 3. PREPARATION OF SAMPLE

- (a) Prepare the sample in accordance with the procedure prescribed in AS1289.1.1;
- (b) Allow the sample to dry sufficiently to enable it to be crumbled. If necessary, dry the sample at a temperature not exceeding 50°C;
- (c) Break up any aggregations of particles in such a way as to avoid crushing any discrete particles. All aggregations of particles are to be broken down so that if the sample were screened on a 4.75mm AS sieve only discrete uncrushed particles would be retained. A rubber pestle should be used to avoid breaking sound pieces of mineral matter. Adhering material should be brushed from coarse pieces. When in doubt as to whether lumps are to be broken, place some in water and boil;
- (d) Weigh the sample to be tested, then screen the sample on a 19.0mm AS sieve, weigh and determine the percentage retained on wet mass basis. Discard material retained;
- (e) Thoroughly remix all material passing the 19.0mm AS sieve and reduce as necessary by quartering or riffing to provide not less than 7,000g of material for preparation of a California Bearing Ratio specimen;
- (f) Where the moisture content of the material being tested is judged to be well below optimum, curing, after initial addition of water may be required. Such initial curing must be carried out prior to the addition of lime;
- (g) Determine the moisture content of a subsample of about 300g after addition of water if applicable.

### 4. PROCEDURE

#### 4.1 Stabilised in the Field

- (a) The sample shall be taken within one hour from the time from the completion of mixing in-situ;
- (b) Immediately after the sample has been taken it shall be sealed in an airtight container, sheltered, and transported as soon as practicable to the laboratory for processing;
- (c) The procedure described in Clause 3 is to be commenced immediately the sample is removed from the airtight container;
- (d) Determine the Maximum Modified Dry Density and Optimum Moisture Content in accordance with NTTM 201.2;
- (e) Incorporate sufficient water to bring the sample to Optimum Moisture Content. Place the mixture in an air tight container and seal. Cure the specimen overnight;
- (f) Compact the specimen in accordance with AS 1289.6.1.1;
- (g) The compaction of the specimen is to be completed within 24 hours of delivery for plant mixed material or, in the case of in-situ work, within 24 hours of the completion of mixing. To achieve this time frame it may be necessary to estimate the Optimum Moisture Content based on wet density and added moisture.

## 4.2 Stabilised in the Laboratory

- (h) Take a test portion of sufficient size (prepared as per Clause 3 above) and determine its mass to the nearest 1g. Calculate the required amount of additive as a percentage by dry mass. Determine the required amount of additive to the nearest 1g;
- (i) Incorporate the prescribed additive as follows: -
  - i. Hydrated Lime: Add the required amount of hydrated lime and thoroughly mix the dry materials to a uniform colour.
  - ii. Quicklime: Add the required amount of quicklime and thoroughly mix the dry materials to a uniform colour. Add a quantity of water equal to about two thirds of the mass of quicklime added to the material. Carefully mix as necessary, observing the safety precautions set out below. Slaking will occur rapidly with generation of heat. The magnitude of the reaction will depend on the amount of quicklime present. Cover the mixture and allow to stand for 10-15 minutes. Remix to break up any lumps, which may have formed.

**See Note 5 for safety precautions related to the use of quicklime.**

- (j) Incorporate sufficient water to provide the Optimum Moisture Content appropriate for the intended compactive effort, as determined by Test Method NTTM 201.2, for the particular lime additive content. Place the mixture in a container and seal. Allow the mixture to cure overnight at room temperature;
- (k) Remove the mixture from the container. Remix, determine its moisture content from a 100g portion using a rapid method and adjust the moisture content, if necessary, to that provided in 4.2(c) above;
- (l) Compact the material in accordance with AS 1289.6.1.1

## 5. CALCULATIONS

Conduct calculations in accordance with AS 1289.6.1.1.

## 6. REPORTING

- (a) Report in accordance with AS 1289.6.1.1;
- (b) Report the Bearing Ratio at 2.5mm and 5.0mm. In all cases the adopted CBR value will be that at 2.5mm.

### **NOTES ON TEST:**

1. Lime used in laboratory investigations should be the same type from the same source of supply or manufacture as the lime proposed for use in the field. Unless otherwise specified or approved, quicklime and hydrated lime shall comply with Australian Standard 1672.1 – 1997 – Limes and Limestone – Limes for Building.
2. Hydrated Lime is the most common form of lime used in lime stabilisation of road materials. It is usually supplied in the form of a fine, white powder and consists essentially of calcium hydroxide. No preparation is required.
3. Quicklime is supplied as ground quicklime, crushed or pebble quicklime, and consists essentially of calcium oxide. Unless supplied in ground form, the material should be ground to pass a 2.36mm AS sieve and stored in an air tight container and protected from moisture until used.

4. Hydrated lime is relatively safe but care is required to protect the eyes when using hydrated lime.
5. **Quicklime may be dangerous in the presence of moisture because of its highly caustic nature. Even small amounts of perspiration on the skin may react with quicklime and cause skin burns. Quicklime is especially dangerous to the eyes. Safety glasses, long sleeved coats and gloves should be worn, and protective cream applied to the hands and arms as required, when using quicklime in the laboratory.**

## CALIFORNIA BEARING RATIO - CEMENT STABILISED MATERIALS

### 1. SCOPE

This test method sets out the procedure for the determination of the California Bearing Ratio of mixtures of materials and cement modified or stabilised in the laboratory.

### 2. APPARATUS

As described in Australian Standard AS1289.6.1.1.

### 3. PREPARATION OF SAMPLE

- (a) Prepare the sample in accordance with the procedure prescribed in AS1289.1.1;
- (b) Allow the sample to dry sufficiently to enable it to be crumbled. If necessary, dry the sample at a temperature not exceeding 50°C;
- (c) Break up any aggregations of particles in such a way as to avoid crushing any discrete particles. All aggregations of particles are to be broken down so that if the sample were screened on a 4.75mm AS sieve only discrete uncrushed particles would be retained. A rubber pestle should be used to avoid breaking sound pieces of mineral matter. Adhering material should be brushed from coarse pieces. When in doubt as to whether lumps are to be broken, place some in water and boil. If slaking occurs, the material should be broken further with the rubber pestle;
- (d) Weigh the sample to be tested, then screen the sample on a 19.0mm AS sieve, weigh and determine the percentage retained on wet mass basis. Discard material retained;
- (e) Thoroughly remix all material passing the 19.0mm AS sieve and reduce as necessary by quartering or riffing to provide not less than 7,000g of material for preparation of a California Bearing Ratio specimen;
- (f) Where the moisture content of the material being tested is judged to be well below optimum, curing, after initial addition of water may be required. Such initial curing must be carried out prior to the addition of cement;
- (g) Determine the moisture content of a subsample of about 300g after addition of water if applicable.

### 4. PROCEDURE

- (a) Take a test portion of sufficient size (as prepared above) and determine its mass to the nearest 1 g. Calculate the required amount of cement as a percentage by dry mass. Weigh out the required amount of cement to the nearest 1g;
- (b) Add the cement to the material and thoroughly mix the dry materials to a uniform colour. Add the quantity of water necessary to provide the optimum moisture content appropriate for the intended compactive effort for the particular cement content. Thoroughly mix. Cover the mixture and allow to stand for not less than 5 minutes and not more than 10 minutes. Remix the materials and break up any lumps that may have formed;
- (c) Place the mixture in a sealed container and allow to cure at a temperature of 23°C ± 2°C for 50-60min. The specimen should be moulded approximately 60-75 minutes after commencement of mixing;
- (d) Compact the material in accordance with AS1289.6.1.1.

**5. CALCULATIONS**

Calculate in accordance with AS1289.6.1.1.

**6. REPORTING**

1. Report in accordance with AS1289.6.1.1;
2. Report the Bearing Ratio at 2.5mm and 5.0mm. In all cases the adopted CBR value will be that at 2.5mm.

**NOTES ON TEST:**

1. Cement used in laboratory investigations should be the same type from the same source of supply or manufacture as the cement proposed for use in the field. Unless otherwise specified or approved, the cement should be Type GP or GB complying with the requirements of AS3972 - Portland and Blended Cements.
2. Cement should be stored in sealed containers and protected from moisture until used. Cement should not be used for laboratory investigations after being stored for a period of three months or longer.
3. The above test procedure may be used for materials stabilised in the field provided the samples are at close to optimum moisture content and the moulding of specimen can be completed within 75min of initial mixing. Samples should be placed in airtight containers and transported to the laboratory immediately. In this case procedures 3(f) and 4(a) are not applicable.

## UNCONFINED COMPRESSIVE STRENGTH OF UNSTABILISED MATERIALS AND MATERIALS STABILISED OR MODIFIED WITH CEMENT, LIME OR BITUMEN

### 1. SCOPE

This test method sets out the procedure for the preparation, curing and determination of unconfined compressive strength of remoulded specimens of soil, gravel or crushed rock material. The procedure may also be used with materials modified or stabilised in the field as well as with materials modified at the quarry.

This method is applicable to materials passing a 19.0 mm AS sieve.

### 2. APPARATUS

- (a) A cylindrical metal mould having an internal diameter of  $105 \pm 0.5$  mm and an internal effective height of  $115 \pm 1$  mm (a volume of approximately 1 litre), fitted with a detachable base-plate and a removable collar assembly approximately 60 mm high, both of which can be firmly attached to the mould. A suitable design is shown in AS 1289.5.2.1;
- (b) (i) A metal rammer with a  $50 \pm 0.5$  mm diameter face and a drop mass of 2.7 kg + 10g - 25g, equipped with a suitable device to control the height of drop to a free fall of  $300 \pm 2$  mm, *or*  
 (ii) A metal rammer with a  $50 \pm 0.5$  mm diameter face and a drop mass of 4.9 kg + 10g, - 30g, equipped with a suitable device to control the height of drop to a free fall of  $450 \pm 2$  mm.

Suitable forms of hand apparatus are shown in AS 1289.5.2.1. Mechanical forms of the apparatus may be used provided the essential dimensions are adhered to;

- (c) A rigid foundation on which to compact the specimen, e.g., a sound concrete floor about 100mm or greater in thickness, or a concrete block of at least 100kg mass;
- (d) A metal mixing and quartering tray;
- (e) Mixing apparatus such as a trowel and palette knife and quartering apparatus, such as metal plates about 400 mm by 125 mm and 200 mm by 125 mm;
- (f) Sample dividers (riffle boxes) of appropriate size openings. (Optional);
- (g) A thermostatically controlled oven with good air circulation, capable of maintaining a temperature within the range of 105°C to 110°C;
- (h) 37.5 mm, 19.0 mm and 4.75 mm AS sieves;
- (i) A balance of at least 6000 g capacity, accurate and readable to 1 g within the operating range;
- (j) A balance of at least 500 g capacity, accurate and readable to 0.01 g within the operating range;
- (k) A jack, lever and frame, or other device, suitable for extruding compacted specimens from the mould;
- (l) A bowl suitable for thoroughly mixing increments of water with the test sample. A mixing machine may be used;
- (m) Moisture measurement containers, at least 500 mL capacity, with press-on lids or other suitable seal;

- (n) A measuring cylinder, 100 mL;
- (o) A steel straightedge; about 300mm long, 25mm wide and 3mm thick, preferably with a bevelled edge;
- (p) A 300mm rule;
- (q) A porcelain mortar, approximately 180mm diameter, and a rubber pestle;
- (r) Metal dishes, approx. 225mm and 350mm diameter;
- (s) A humidity cabinet capable of maintaining a humidity of not less than 90 per cent at a temperature within the range of 21°C to 25°C. Alternatively, a water bath equipped with a snug-fitting lid and perforated metal false bottom with supports to provide a 50mm space below the perforated plate;
- (t) Materials and equipment for measuring and capping cylindrical test specimens, such as callipers, engineers tri-square, plate glass about 125 mm by 125 mm, a spirit level approximately 100 mm long, plaster of paris or orthopaedic plaster, small trowel or palette knife, mixing dish, etc.;
- (u) A compression testing machine of at least 60 kN capacity complying, as regards accuracy, with the requirements of AS 2193 (Methods for the Calibration of Testing Machines) for Grade C machines. The upper bearing block of the machine shall have a spherical seat.

### **3. PREPARATION OF SAMPLE**

- (a) Break up any aggregations of particles in such a way as to avoid crushing any discrete particles. All aggregations of particles are to be broken down so that if the sample were screened on a 4.75mm AS sieve only discrete, uncrushed particles would be retained. A rubber pestle should be used to avoid breaking down sound pieces of mineral matter. Adhering material should be brushed from coarse pieces. When in doubt as to whether lumps are to be broken, place some in water and boil. If slaking occurs, the material should be broken further with a rubber pestle;
- (b) Weigh the sample to be tested and screen the sample on a 37.5mm and 19mm AS sieve. Weigh, then discard material retained. Calculate percentage retained on each of the two sieves;
- (c) Thoroughly mix all material in the portion passing the 19.0 mm AS sieve, and obtain by quartering or riffing a portion of no less than 6000g of material for preparation of a pair of test specimens;
- (d) Where the moisture content of the material is judged to be well below optimum, overnight curing may be required after initial addition of water. This curing should be carried out before the addition of the stabilising agent.

### **4. PREPARATION OF ADDITIVES**

#### **4.1 Lime**

Lime used in laboratory investigations should be the same type from the same source of supply or manufacture as the lime proposed for use in the field. Unless otherwise specified or approved, quicklime and hydrated lime shall comply with Australian Standard 1672.1 – Limes and Limestone: Limes for Building.

- (a) Hydrated Lime is the most common form of lime used in lime stabilisation of road materials. It is usually supplied in the form of a fine, white power and consists essentially of calcium hydroxide. No preparation is required;

- (b) Quicklime is supplied as ground quicklime, crushed or pebble quicklime, and consists essentially of calcium oxide. Unless supplied in ground form, the material should be ground to pass a 2.36mm AS sieve and stored in an air-tight container and protected from moisture until used;

**See Note 1 for safety precautions related to the use of quicklime.**

- (c) Hydrated lime – pozzolan mixtures are prepared by mixing the dry materials in the desired proportions by mass and storing the mixture in an air-tight container protected from moisture until used;
- (d) Determine if directed, the available lime expressed as calcium oxide and calcium hydroxide, as described in Test Method NTTM 204.6 for the lime used in the laboratory testing.

## 4.2 Cement

Cement used in laboratory investigations should be the same type from the same source of supply or manufacture as the cement proposed for use in the field.

Cements must be stored in sealed containers and protected from moisture until used. Cement should not be used for laboratory investigations after being stored for a period exceeding three months.

## 5. PREPARATION AND CURING OF TEST CYLINDERS

- (a) Obtain, by quartering or riffing, two portions, each of about 3000g mass, from the sample prepared in 3(c) above;
- (b) Take one of the 3000g portions. Determine its moisture content using a minimum 300g sample in accordance with AS1289.2.1.1;
- (c) Determine the dry mass of the remainder of the 3000g portion to the nearest 1g;
- (d) Clauses (e), (f) and (h) do not apply when testing unstabilised materials;
- (e) Calculate the required amount of the prescribed additive, as a percentage of the calculated dry mass of the test portion, to the nearest 1g. Weigh out this quantity of additive;
- (f) Add the calculated amount of prescribed additive to the test portion, thoroughly mixing the materials to a uniform colour;

Where the prescribed additive is quicklime, add a quantity of water equal to about two thirds of the mass of the quicklime added to the material. Carefully mix as necessary, observing the safety precautions set out in Note 1 of this test method. Slaking will occur rapidly with generation of heat. The magnitude of the reaction will depend on the amount of quicklime present. Cover the mixture and allow to stand for 10-15 minutes. Re-mix to break any lumps that may have formed;

- (g) Add sufficient water to provide optimum moisture content, appropriate for the intended compactive effort, for the particular material and quantity of additive, if any, based on the dry mass of soil. Thoroughly mix;
- (h) Curing prior to compaction.
  - i. **Cement Modified;** Materials should be compacted as soon as practicable after the addition of cement and not later than 60-75min from mixing;



- ii. **Bitumen Modified;** Materials should be compacted as soon as practicable after the addition of the bituminous material;
  - iii. **Lime Modified;** Materials should be placed in sealed container and allowed to cure overnight at room temperature.
- (i) Weigh the mould and record the mass ( $M_2$ ) to the nearest 5g. Assemble the mould, collar and base plate and place the assembly on the rigid foundation. The interior of the mould should be oiled with a light application of oil. Wipe off any excess oil;
  - (j) Compact the mixture into the mould by the specified compactive effort;
    - i. **Standard Compaction;** Compact the mixture into the mould in three approximately equal layers not varying in compacted thickness by more than 5mm. Subject each layer to 25 uniformly distributed blows of a 2.7kg rammer falling freely from a height of 300mm,  
*or*
    - ii. **Modified Compaction;** Compact the mixture into the mould in five approximately equal layers not varying in compacted thickness by more than 5mm. Subject each layer to 25 uniformly distributed blows of a 4.9kg rammer falling freely from a height of 450mm.
  - (k) Use only sufficient material to slightly overfill the mould, leaving not more than 5mm to be struck off after removing the collar;
  - (l) With a quantity of not less than 300 g from the excess mixed and moistened material, check the moisture content as set out in Clause 5 (b);
  - (m) Free the material from around the collar of the mould assembly and then carefully remove the collar;
  - (n) Level the compacted specimen to the top of the mould by means of the straightedge. Patch with smaller sized material any holes developed in the surface by removal of coarse material. Make up a slurry of some of the excess material and trowel the slurry on the top surface of the specimen to provide a smooth, level surface, taking care to ensure that the surface is plane within 0.1 mm to avoid the need for capping;
  - (o) Remove the base-plate and weigh the mould plus compacted specimen and record the mass ( $M_1$ ) to the nearest 1g;
  - (p) Carefully eject the compacted specimen from the mould. Stand the compacted specimen on a filter paper in a dish and place in a humidity cabinet or suitable water bath;
  - (q) Repeat processes 5 (b) to 5 (p) with the other 3000g portion to provide a duplicate specimen;
  - (r) Cure the specimens as specified, e.g. 7 days or 28 days;
  - (s) On completion of the period of curing, immerse each test specimen in water at room temperature for 4 hours. The specimen should be covered by at least 10mm of water so that entrapped air may escape. Allow to drain for 15 minutes.

## 6. CAPPING OF TEST SPECIMENS

- (a) Examine the condition of the surfaces of the test specimen. If cracking has occurred, at the junction of layers, the specimen should be discarded. Cap the ends of cylinders which are:
  - i. More than 2° out of square from the axis; *and/or*,
  - ii. Which have small depressions or other irregularities that would cause the load to be applied over 90% or less of the surface area;

- (b) Cap the test specimen if required, with a thin layer of plaster, preferably orthopaedic plaster;
- (c) Allow the test specimen to stand at constant moisture content for one hour and then subject to the compression test.

## 7. COMPRESSION TESTING

- (a) Determine the average diameter ( $D_m$ ) of the test specimen to the nearest 0.5mm from two diameters measured at right angles to each other near the centre of the height of the cylinder;
- (b) Place the test specimen on the lower bearing block of the compression testing machine, making sure that the vertical axis of the test specimen is aligned with the centre of thrust of the upper bearing block. Bring the upper bearing block to bear on the test specimen and ensure that uniform seating is obtained;
- (c) Apply the load continuously at a uniform rate of  $0.10 \pm 0.02$  MPa per second. Record the load at failure of the test specimen to the nearest 0.5 kN.

## 8. CALCULATIONS

- (a) Calculate the mass of the test specimen as compacted ( $M_3$ ), as follows:-

$$M_3 = (M_1 - M_2)g$$

- (b) Calculate the moisture content ( $w$ ) of the test specimen as compacted, as follows:-

$$w = \frac{A - B}{B - C} \times 100$$

Where  $w$  = percentage of moisture in test specimen,

$A$  = mass of moisture tin + wet sample,

$B$  = mass of moisture tin + oven-dry sample,

$C$  = mass of moisture tin.

- (c) Calculate the dry density of the test specimen as compacted, as follows:-

$$\text{Dry Density} = \frac{M_3 \times 0.1}{100 + w} \text{ t/m}^3$$

- (d) Calculate the unconfined compressive strength of the test specimen as follows:-

$$\text{UCS(MPa)} = \frac{\text{Load (kN)} \times 1000}{\text{Area(mm}^2\text{)}} = \frac{\text{Load (kN)} \times 1273}{(D_m)^2}$$

Where  $D_m$  = average diameter in mm.

## 9. REPORTING

Report the following data for each pair of test specimens as appropriate: -

- (a) Type and source of additive;
- (b) Additive content;
- (c) Moisture content at which specimens were compacted;
- (d) Compactive effort applied;
- (e) Dry density of test specimens as compacted in  $t/m^3$  to the nearest  $0.01 t/m^3$ ;
- (f) Period and conditions of curing;
- (g) Period of soaking;
- (h) Condition of specimens, i.e. moist or dry after curing;
- (i) Unconfined compressive strength, as the average of the strengths of duplicate test specimens, in MPa to the nearest 0.05 MPa;
- (j) Percentage of materials retained on 37.5mm and 19mm AS sieves.

## 10. TECHNIQUES

The height of each layer should be checked with a gauge or rule to ensure that the layer is about one-third (or one-fifth) of the height of the mould. If the final layer is more than 5 mm above the top of the mould after removing the collar, the specimen should be rejected.

Slightly scarify the top surface of the first and second layers, before adding the next layer, to ensure adequate bonding between layers.

### NOTES ON TEST

1. **Quicklime may be dangerous in the presence of moisture because of its highly caustic nature. Even small amounts of perspiration on the skin may react with quicklime and cause skin burns. Quicklime is especially dangerous to the eyes. Safety glasses, long sleeved coats and gloves should be worn, and protective cream applied to the hands and arms as required, when using quicklime in the laboratory.**
2. Hydrated lime is relatively safe, but care is required to protect the eyes when using hydrated lime.
3. The coarser particles of quicklime may hydrate slowly after compaction. In some cases, the resulting volume increase will cause compacted specimens to disintegrate. Potential problems associated with volume increase on hydration are best highlighted during laboratory testing, stressing the importance of using the same additive (of the same grading) as will be used in the field.
4. The exclusion of a large proportion of stone coarser than 19.0mm may have a major effect on the unconfined compressive strength determined, compared with that obtainable with the material as a whole.
5. The chemical reactions producing cementitious compounds only take place in the presence of moisture. Strength development ceases when the material dries out. It is therefore essential that the specimens are kept moist during the curing phase. Results from specimens which have dried out during the curing phase should be treated with considerable caution.

## CEMENT CONTENT OF STABILISED MATERIALS – HEAT OF NEUTRALISATION METHOD

### 1. SCOPE

This method describes a procedure for the quick determination of the cement content of fresh mixtures of gravel or fine crushed rock and cement. This method is not appropriate for limestone. It is based on the measurement of the heat of neutralisation of the cement. After preparation of a calibration curve, results may be obtained within ten minutes of sampling.

### 2. APPARATUS

- i. Shovel;
- ii. Sample splitter, having 50mm slots;
- iii. Scoop;
- iv. Plastic jar, with approximately 4.5 litres capacity and 10cm opening, and a screw-on water tight lid;
- v. Large plastic container, of approximately 20 litre capacity for buffer solution;
- vi. Measuring cylinder, of 1.5 litre capacity;
- vii. Thermometer – 0 - 50°C readable to 0.2°C;
- viii. Balance, of at least 6000g capacity and accurate and readable to at least 10g;
- ix. Beakers;
  - 1 x 250ml capacity for weighing cement \*
  - 1 x 500ml capacity for weighing water \*
  - 1 x 5 litre capacity for mixing buffer \*
  - \* Only necessary for calibration

### 3. REAGENTS

- (a) Anhydrous sodium acetate ( $\text{CH}_3\text{COONa}$ ) (Technical grade);
- (b) Glacial acetic acid ( $\text{CH}_3\text{COOH}$ ) (Technical grade).

### 4. MATERIALS

- (a) A representative sample of at least 40kg of the fine crushed rock/gravel to be used;
- (b) A sample of about 1.5kg of the cement to be used.

### 5. REQUIRED INFORMATION

- (a) The moisture content to be used in the material for the job i.e. percent mass per mass of dry crushed rock/gravel;
- (b) The job target cement content to be used in the material for the job i.e. percent mass per mass of dry crushed rock/gravel.

### 6. PREPARATION OF BUFFER SOLUTION

One litre of buffer solution shall be prepared for each test and for each point on the calibration curve.

- i. For each litre of buffer solution, 250g of sodium acetate, 240g of glacial acetic acid, and about 500ml of potable water shall be mixed until all solids have dissolved;
- ii. The solution shall then be made up to 1000ml with potable water.

## 7. PREPARATION OF CALIBRATION CURVE

Six percentages of cement contents shall be chosen around the job target cement content. For example, if the target figure is 2% cement, then percentages of 1.0, 1.5, 2.0, 2.5, 3.0 and 3.5 shall be used.

For each of these percentages the following procedure shall be carried out:

- i. The mass of crushed rock/gravel, cement and water shall be calculated so that the total mass is 5000g (see Note 1). Start with the highest percentage of cement required for calibration (see Note 2);
- ii. The calculated mass of crushed rock shall be weighed into the plastic jar, and the cement and water weighed into separate beakers;
- iii. The cement shall be added to the crushed rock and the mix shaken;
- iv. The water shall then be added and the mix shaken for exactly 2 minutes;
- v. The thermometer shall be pushed carefully into the mixture and the temperature (A)°C shall be read after 60 seconds;
- vi. The measuring cylinder shall be filled to the 1000ml mark with the buffer solution, (see Note 2);
- vii. The thermometer shall be placed in the solution and the temperature (B)°C shall be read after 60 seconds;
- viii. The buffer shall be poured into the mix in the plastic jar and the mixture shaken for exactly 4 minutes;
- ix. The thermometer shall be pushed carefully into the mixture and the temperature (C)°C shall be read after 60 seconds;
- x. The temperature rise (DT) shall be calculated using the following equation:-

$$DT = C - \frac{A+B}{2}$$

where DT = Temperature Rise °C  
 A = Initial temperature of mix °C  
 B = Initial temperature of buffer °C  
 C = Final temperature of buffer and mix °C

- xi. Temperature rise (DT) shall be plotted against the cement content (percent by mass of dry crushed rock/gravel).

## 8. TEST PROCEDURE

- (a) A sample of the mix shall be obtained as soon as possible after mixing;
- (b) For example, a shovel may be held under the pugmill where the mix pours into the truck or storage hopper. The quantity of sample should be approximately 20kg. The sample shall be split through the sample splitter until a 5kg sample is obtained;
- (c) The subsample of 5kg shall be weighed into the plastic jar, and the temperature (A)°C recorded after 60 seconds;
- (d) The measuring cylinder shall be filled to the 1000ml mark with buffer solution, and the temperature (B)°C recorded after 60 seconds;
- (e) The buffer shall be added to the mix in the plastic jar, and the mixture shaken for exactly 4 minutes;
- (f) The thermometer shall be carefully pushed into the mix and the temperature (C)°C recorded after 60 seconds;
- (g) The temperature rise (DT) shall be calculated as in section 7 (x).

**9. REPORTING**

The cement content corresponding to the temperature rise shall be read from the calibration graph and reported as a percentage, by mass of dry crushed rock/gravel, to the nearest 0.1%.

**NOTES:**

1. Example of calculation of mass of crushed rock/gravel, cement and water.

For Cement Content 2% and Moisture Content 8%.

Let mass of crushed rock/gravel =  $x$  g

$$\text{then mass of water} = \frac{8x}{100} = 0.08x \text{ g}$$

$$\text{and mass of cement} = \frac{2x}{100} = 0.02x \text{ g}$$

$$\text{Total mass} = x_g + 0.08x_g + 0.02x_g = 1.10x_g$$

$$\text{Therefore } 1.10x_g = 5000\text{g}$$

$$\text{Therefore mass of crushed rock/gravel } x = \frac{5000}{1.1} = 4545.5\text{g}$$

$$\text{and mass of water} = 0.08x_g = 0.08 \times 4545.5 = 363.6\text{g}$$

$$\text{and mass of cement} = 0.02x_g = 0.02 \times 4545.5 = 90.9\text{g}$$

2. For high percentages of cement (about 3.5% and above), the rock/gravel, cement and buffer mixture may gel into a solid mass, thus preventing proper mixing. If percentages above 3.5 are expected, then 1500ml of buffer solution should be used instead of 1000ml, for all calibration points and tests.

## DETERMINATION OF THE LIME SATURATION POINT OF STABILISED MATERIALS - pH METHOD

### 1. SCOPE

This test method sets out the procedure for the determination of the approximate percentage of hydrated lime required to saturate a soil or gravel. This information may be applied in the determination of suitable additive contents in soil modification and stabilisation investigations.

### 2. APPARATUS

- (a) 19.0mm, 9.50mm and 4.75mm A.S. sieves;
- (b) A balance of at least 1kg capacity accurate and readable to 0.1g within the operating range;
- (c) A balance of at least 500g capacity accurate and readable to 0.01g within the operating range;
- (d) Metal dishes, approximately 100mm, 225mm and 350mm diameter;
- (e) A mixing and quartering tray;
- (f) Mixing apparatus such as a trowel, spatula, and quartering apparatus such as metal plates 400mm by 125mm and 200mm by 25mm;
- (g) Sieve brushes;
- (h) A porcelain mortar, 178mm diameter with porcelain and rubber pestles;
- (i) Sample dividers (riffle boxes) with appropriate size openings (optional);
- (j) A thermostatically controlled oven with good air circulation, capable of maintaining a temperature not exceeding 50°C;
- (k) Desiccators, preferable cabinet type;
- (l) A pH meter with a scale accurate and readable to 0.1 pH unit complete with alkaline-type electrodes;
- (m) Beakers 250ml;
- (n) Rubber-tipped glass stirring rods.

### 3. REAGENTS

- (a) A quantity of fresh hydrated lime;
- (b) Freshly boiled distilled or de-ionised water.

### 4. PREPARATION OF THE SAMPLE

- (a) Allow the sample to dry sufficiently to enable it to be crumbled. If necessary, dry the sample in an oven at a temperature not exceeding 50°C;
- (b) Break up any aggregations of particles in such a way as to avoid crushing any discrete particles. All aggregations of particles are to be broken down so that if the sample were screened on a 2.36mm A.S. sieve, only discrete uncrushed particles would be retained. A rubber pestle should be used to avoid breaking down sound pieces of mineral matter. Adhering material should be brushed from coarse pieces. When in doubt as to whether lumps are to be broken, place some in water and boil. If slaking occurs, the material should be broken further with a rubber pestle;
- (c) Reduce the sample, as necessary, by quartering or riffing, to provide an amount sufficient to yield not less than 500g of material passing a 4.75mm A.S. sieve;
- (d) Screen the sample on a 4.75mm A.S. sieve. To facilitate this operation and to avoid overloading of sieves, screen the sample on a 19.0mm and 9.50mm A.S. sieve prior to separation on a 4.75mm A.S. sieve.

## 5. PROCEDURE

- (a) Determine the available lime content of the lime to be used in the laboratory investigation, in accordance with the procedure described in Test Method: NTTM 204.6;
- (b) Quarter the sample of soil obtained in 4 (c) above to yield eight sub-samples of approximately 50g each;
- (c) Weigh each sub-sample and record its mass;
- (d) Place one sub-sample in a 250ml beaker;
- (e) Add a quantity of hydrated lime to each of the other sub-samples so that the proportion of hydrated lime varies from sub-sample to sub-sample by 1% by mass;
- (f) Thoroughly mix the lime into the soil in each of the sub-samples and transfer the soil-lime mixtures to 250ml beakers;
- (g) Add 100ml freshly boiled distilled or de-ionised water to each beaker, including that containing soil only;
- (h) Stir each beaker of material vigorously for 1 minute. Ensure that all of the material in each beaker is uniformly mixed (ie. all the material has been wetted);
- (i) After 10 minutes remix each beaker for a further one minute and repeat this procedure six times;
- (j) Place 4 g of hydrated lime in a 250ml beaker and add 100ml freshly boiled distilled or de-ionised water and mix vigorously for two minutes. Remix as in (i) above keeping the beaker covered between mixes;
- (k) Using the manufacturer's instructions for the particular pH meter being used, determine the pH of the soil-water mixtures after completion of the last mixing in (i) and (j) above;
- (l) If the pH of the sub-sample with the highest percentage of added lime does not equal the pH of the lime-water mixture, make up a further mixture of soil plus lime, varying the lime content so that the final pH is at least equal to that of the lime-water mix;
- (m) Prepare a graph of pH versus percentage by mass of lime added to the soil. Draw in the line of pH corresponding to the pH of the water-lime mix.

## 6. CALCULATIONS

- (a) Determine from the graph the percentage of lime ( $L_1$ ) required to saturate the sample. This is the point of intersection of the pH versus added lime graph and the line of pH of the water-lime mix;
- (b) Calculate the percentage of material (P) passing the 4.75mm sieve;
- (c) Calculate the percentage of lime ( $L_2$ ) needed to saturate the whole soil as follows:-

$$L_2 = \frac{L_1 \times P}{100}$$

**NOTE:** This then represents the mid-point of the range of lime percentages to be used in stabilisation investigations.

## 7. REPORTING

- (a) Report the available lime content (expressed as calcium hydroxide) of the lime used in the laboratory investigation;
- (b) Report to the nearest 0.5% the percentage of lime, by mass, needed to saturate the whole soil.



**8. TECHNIQUE**

In cases where the pH of the lime-soil mixes will not attain the pH of the water-lime mix, take  $L_1$  to be equal to the percentage of lime where the graph of pH versus lime-content reaches a plateau.

## AVAILABLE CALCIUM OXIDE OR CALCIUM HYDROXIDE IN LIME

### 1. SCOPE

This test method sets out the procedure for determining the available calcium hydroxide ( $\text{Ca}(\text{OH})_2$ ) or calcium oxide ( $\text{CaO}$ ) in hydrated lime or quicklime respectively.

### 2. APPARATUS

- (a) Laboratory glassware including pipettes, burettes, volumetric flasks, etc;
- (b) A balance of suitable capacity with a limit of performance of 0.005g;
- (c) 300 $\mu\text{m}$  AS sieve;
- (d) Hot Plate.

### 3. REAGENTS

- (a) Sucrose Solution;

Dissolve 100g sucrose in 200mL of  $\text{CO}_2$  - free distilled water. Add several drops of phenolphthalein indicator solution. Titrate with 0.1 M NaOH solution dropwise while stirring until a faint pink colour persists. This solution should not be kept for more than 2 days;

- (b) Sodium Hydroxide Solution (0.1M). Dissolve 0.4g NaOH in water and dilute to 100 mL;

**CAUTION: Sodium Hydroxide is very alkaline and corrosive and can cause severe burns. Avoid contact with skin, eyes and clothing. If the solution is spilt, wash off immediately with water. Safety glasses must be worn.**

- (c) Indicator: (4 per cent phenolphthalein);

Dissolve 4g of dry phenolphthalein in 100mL of 95% ethanol;

- (d) Hydrochloric Acid Solution (0.5M). Dilute 50mL of concentrated AR hydrochloric acid with water to 1000mL in a volumetric flask. Standardise against sodium carbonate or borax (an example of a procedure is given in Vogel - "Quantitative Inorganic Analysis")

**CAUTION: Hydrochloric acid is corrosive, handle with care. Always add acid to water, NEVER the reverse. Safety glasses must be worn.**

### 4. SAMPLE PREPARATION

In the case of quicklime, take a representative sample and crush as rapidly as possible to a size passing a 300  $\mu\text{m}$  AS sieve and place in a sealed container until required for testing. Testing should be carried out as soon as possible.

**CAUTION: Quicklime is very corrosive in contact with moisture. Avoid breathing the dust when crushing and sieving by wearing a face mask.**

**5. PROCEDURE**

- (a) Accurately weigh about 0.5g of the sample passing 300µm AS sieve and carefully add to a 250mL Erlenmeyer flask containing 10mL of cold CO<sub>2</sub> - free distilled water and immediately stopper the flask. When testing hydrated lime, proceed to Procedure (d);
- (b) Place the flask on a hot plate, remove the stopper and immediately add 50mL of boiling CO<sub>2</sub> - free distilled water to the flask. Swirl the flask and boil actively for 1 minute for complete slaking;
- (c) Remove from the hot plate, stopper the flask loosely, and place in a cold water bath to cool to room temperature;
- (d) Add 60mL of sucrose solution. Stopper the flask, swirl and let stand for 10 to 20 minutes, swirling at 5 minute intervals;
- (e) Remove stopper, add 4 to 5 drops of indicator and titrate rapidly (in the original flask) with the hydrochloric acid solution. When the first complete disappearance of the pink colour is noted, read the end point;
- (f) Repeat Procedure (a) to (e) with a second sub-sample of lime.

**6. CALCULATIONS**

- (a) As calcium hydroxide;

$$\text{Percent of lime} = 0.037 \times T \times \frac{M}{w} \times 100$$

- (b) As calcium oxide;

$$\text{Percent of lime} = 0.028 \times T \times \frac{M}{w} \times 100$$

Where T = volume of acid used to titrate the sample (mL).

M= molarity of the acid used.

W= mass of sample (g).

- (c) Calculate the available calcium oxide or calcium hydroxide to the first decimal place and take the mean of the two determinations.

**7. REPORTING**

Report the following:

- (a) Type of lime tested;
- (b) Source of lime;
- (c) For quicklime, available lime expressed as calcium oxide rounded off to the nearest whole number. Values of 0.5 are to be rounded up;
- (d) Or for hydrated lime, available lime expressed as calcium hydroxide rounded off to the nearest whole number. Values of 0.5 are to be rounded up.

**8. ALTERNATIVE PROCEDURE**

- (a) 0.25 M oxalic acid may be used as an alternative to 0.5 M hydrochloric acid when a standard solution is not available. Make up the 0.25M oxalic acid solution by dissolving 31.5g  $\text{H}_2\text{C}_2\text{O}_4 \cdot 2\text{H}_2\text{O}$  in 1 litre of distilled water. This solution need not be standardised.

**CAUTION: Oxalic acid is very poisonous by ingestion. Avoid contact with skin and as a precaution wash hands after handling.**

In this case the calculations are:

- (i) As calcium hydroxide

$$\text{Percent of lime} = 0.074 \times T \times \frac{M}{W} \times 100$$

- (ii) As calcium oxide

$$\text{Percent of lime} = 0.056 \times T \times \frac{M}{W} \times 100$$

Where	T	=	volume of acid used to titrate the sample (mL).
	M	=	molarity of the acid used.
	W	=	mass of sample (g).

## RATE OF SPREAD OF LIME OR CEMENT

### 1. SCOPE

This test method sets out the procedure for determining the rate of spread of lime or cement used in soil modification or stabilisation. This procedure is only applicable where the lime or cement is spread by means of a mechanical spreader.

### 2. APPARATUS

- (a) A balance of 10kg capacity, accurate and readable to 1g within the operating range;
- (b) Galvanised iron trays, as required, with internal measurements 1,000mm x 300mm with sides approximately 40mm high.

### 3. PROCEDURE

- (a) Place the metal tray on the pavement to be modified or stabilised with its long side parallel to the edge of the pavement. Ensure that the wheels of the mechanical spreader will not touch the tray;
- (b) Remove the tray immediately after the spreader has passed over the tray and record the mass of the lime or cement retained in the tray to the nearest 1g.

### 4. CALCULATION

- (c) Calculate rate of spread of lime or cement (R), as follows:-

$$R = \frac{M}{300} \text{ kg/m}^2$$

where M = mass (in grams) of material retained on tray.

### 5. REPORTING

Report the rate of spread of lime or cement to the nearest 0.01kg/m<sup>2</sup>.

## STABILISER DISTRIBUTION

### 1. SCOPE

This method describes the procedure for the determination of the vertical and/or horizontal distribution of stabiliser content for the full thickness of pavement layers.

### 2. PREPARATION

- (a) Determine the thickness of the pavement in accordance with NTTM 216.1;
- (b) Select test sites as necessary in accordance with NTCP 103.1;
- (c) At each test site, select three evenly spaced test locations across the run;
- (d) At each test location divide the thickness of the layer into 2. (Top half and bottom half), for vertical distribution of stabiliser.

### 3. PROCEDURE

Determine the Stabiliser Content of both the top half and the bottom half of the layer, in accordance with the relevant Northern Territory Test Methods or Australian Standards.

### 4. REPORT

Report the following for each test location:

- (a) Location;
- (b) Layer thickness;
- (c) Stabiliser Content of top half;
- (d) Stabiliser Content of bottom half.

## DURABILITY - CEMENT STABILISED MATERIALS

### 1. SCOPE

This test method sets out the procedure for the determination of the durability of soil, gravel or crushed rock material modified or stabilised in the laboratory by the addition of cement using modified compaction.

### 2. APPARATUS

- (a) As described in AS1289.5.2.1;
- (b) A humidity cabinet capable of maintaining a humidity of not less than 90 per cent at a temperature within the range of 21°C to 25°C. Alternatively, a water bath equipped with a snug fitting lid and perforated metal false bottom with supports to provide a 50mm space below the perforated plate;
- (c) Water bath;
- (d) Steel bristle wire brush with 30mm minimum length bristles.

### 3. PREPARATION OF SAMPLE

- (a) Allow the sample to dry sufficiently to enable it to be crumbled. If necessary, dry the sample at a temperature not exceeding 50°C;
- (b) Break up any aggregations of particles in such a way as to avoid crushing any discrete particles. All aggregations of particles are to be broken down so that if the sample was screened on a 4.75mm AS sieve, only discrete uncrushed particles would be retained. A rubber pestle should be used to avoid breaking down sound pieces of mineral matter. Adhering material should be brushed from coarse pieces. When in doubt as to whether lumps are to be broken, place some in water and boil. If slaking occurs, the material should be broken further with a rubber pestle;
- (c) Screen the sample on a 19.0mm AS sieve. Discard material retained;
- (d) Thoroughly mix all material passing the 19.0mm AS sieve, and reduce, as necessary, by quartering or riffing, to provide not less than 5000g of material for each cement content.

### 4. CEMENT

- (a) Cement used in laboratory investigations should be the same type from the same source of supply or manufacture as the cement proposed for use in the field;
- (b) Cement should be stored in sealed containers and protected from moisture until used. Cement should not be used for laboratory investigations after being stored for a period of three months or longer.

### 5. PROCEDURE

- (a) Obtain, by quartering or riffing, two 2500 g portions, of the sample prepared in 3(d) above;
- (b) Weigh the mould and record the mass ( $M_2$ ) to the nearest 5g;
- (c) Assemble the mould, collar and base-plate and place the assembly on the rigid foundation;

- (d) Take one of the 2500g portions and determine the mass to the nearest 1g. Screen on a 4.75mm A.S. sieve. All material retained on the 4.75mm A.S. sieve shall be soaked for at least one hour and then surface dried;
- (e) Add the required amount of cement, calculated as a percentage of the dry mass of the sample determined in 5 (d), to the material passing the 4.75mm A.S. sieve and thoroughly mix the dry materials to a uniform colour. Add a small quantity of water (approximately 5 per cent by mass for sandy or gravelly materials and 8 per cent for clayey materials) and mix. Incorporate the saturated surface dry material retained on the 4.75mm A.S. sieve and remix. Add water to bring the sample to its optimum moisture content. Cover the mixture and allow to stand for not less than 5 minutes but not more than 10 minutes. Thoroughly remix the material;
- (f) Compact the mixture into the mould at the optimum moisture content for the specified compactive effort;
- (g) Use only sufficient material to slightly overfill the mould leaving not more than 5mm to be struck off after removing the collar. Free the material from around the collar and then carefully remove the collar;
- (h) Level the compacted material to the top of the mould by means of the straightedge. Patch with smaller sized material any holes developed in the surface by removal of coarse material;
- (i) Remove the base-plate and weigh the mould plus compacted material and record the mass ( $M_1$ ) to the nearest 5g;
- (j) Carefully extrude the sample from the mould;
- (k) Cure the specimens for 7 days from the time of compaction at not less than 90 per cent humidity at a temperature within the range of 21°C to 25°C;
- (l) Repeat processes (b) to (j) for the other portion. One cylinder (SPECIMEN 1) shall be used in subsequent testing for volume and moisture content changes and the other cylinder (SPECIMEN 2) shall be used in subsequent testing for loss by abrasion;
- (m) Immerse the cylinders in a water bath at room temperature for 5 hours. On removal from the water the cylinders shall be weighed to nearest 5g and the height and diameter measured to the nearest 5mm to obtain the volume;
- (n) Place the cylinders in an oven at 65°C to 70°C for 42 hours;
- (o) Remove the cylinders from the oven;
- (p) Weigh SPECIMEN 1, measure the diameter and height and determine moisture content and volume changes;
- (q) Abrade SPECIMEN 2 with two firm strokes with a wire bristled brush on each part of the side and ends of the cylinder. The brush shall be applied to the full length and breadth of the specimen. Approximately 18 to 20 vertical strokes are necessary on the side and 2 are required on each end of the cylinder. Weigh the specimen after abrasion and compute the loss in mass as a percentage of the original mass;
- (r) Repeat the procedure set out in (m) to (o) for another 11 cycles;
- (s) On completion of the 12 cycles dry the cylinders to constant mass ( $M_4$ ) at 105°C to 110°C and determine the moisture content ( $w$ ) of each specimen;
- (t) Repeat the procedure for each of the specified cement contents.

## 6. CALCULATIONS

- (a) Calculate the mass of compacted material ( $M$ ) after compaction, as follows:-

$$M = (M_1 - M_2) \text{ g}$$

- (b) Calculate the change in volume of SPECIMEN 1 (as a percentage by volume) as follows:-

$$V = \frac{1000 - V_{12}}{10}$$



Where  $V$  = volume change (per cent)

$V_{12}$  = volume of specimen after completion of 12 cycle of wetting and drying ( $\text{cm}^3$ ).

- (c) Calculate the change in mass of SPECIMEN 1 (as a percentage by mass) as follows:

$$M_c = \frac{M - M_{12}}{M} \times 100\%$$

Where  $M_c$  = change in mass (per cent)

$M$  = mass of material after compaction (g)

$M_{12}$  = mass of material after 12 cycles of wetting and drying (g)

- (d) Calculate the loss in mass of SPECIMEN 2 (as a percentage by mass) after abrasion as follows:

$$M_A = \frac{M - M_{12}}{M} \times 100\%$$

Where  $M_A$  = loss of mass (per cent).

$M$  = mass of material after compaction

$M_{12}$  = mass of material after 12 cycles of wetting and drying

- (e) Calculate the final moisture content of the specimens (as a percentage by mass) as follows:

$$w = \frac{M_{12} - M_4}{M_4} \times 100\%$$

Where  $w$  = moisture content

$M_{12}$  = mass after 12 cycles of wetting and drying (g)

$M_4$  = dry mass after 12 cycles of wetting and drying (g)

- (f) Calculate the change in moisture content of the specimens as follows:

$$W = \frac{w - O_{Mc}}{O_{Mc}} \times 100\%$$

Where  $W$  = change in moisture content (per cent).

$w$  = final moisture content from (e)

$O_{Mc}$  = optimum moisture content as determined by Test Method NTTM 201.3.

**7. REPORTING**

Report the following results for each cement content as appropriate:

- (a) Type and source of cement;
- (b) Cement content as a percentage by mass;
- (c) Compactive effort applied;
- (d) Optimum moisture content;
- (e) Change in volume after 12 cycles of wetting and drying;
- (f) Change in mass after 12 cycles of wetting and drying;
- (g) Change in mass after 12 cycles of wetting and drying and abrasion;
- (h) Change in moisture content.

## PLATE BEARING TEST

### 1. SCOPE

This method covers the estimating of the bearing value of soil in place by means of field loading tests. This test is only a part of the necessary procedure for soil investigation for foundation design. It gives information on the soil only to a depth equal to about two diameters of bearing plate, and takes into account only part of the effect of time.

### 2. APPARATUS

The apparatus shall include the following:

- (a) Loading Platforms or Bins, of sufficient size and strength to supply the estimated total load required, or equivalent means of supplying the total load reaction anticipated;
- (b) Hydraulic or Mechanical Jack Assembly of sufficient capacity to provide the maximum estimated load on the largest plate for the specific soil conditions involved, but not less than 50 tonnes in any case, and a device for measuring the force exerted by the jack. If a hydraulic jack is used without other force measuring device, it should be equipped with a pressure gauge capable of recording the jack load to an accuracy of  $\pm 2$  per-cent and should be recently calibrated with the jack to ensure an accuracy of  $\pm 2$  per-cent for the assembly. If a pressure-measuring device is to be interposed between the jack and the reaction, it should be capable of recording the load with an accuracy of at least  $\pm 2$  per-cent;
- (c) Bearing Plates. - Three circular steel bearing plates, not less than 25mm in thickness and varying in diameter from 200 - 750mm, including the minimum and maximum diameter specified;
- (d) Dial Gauges, or other settlement-recording devices, capable of measuring settlement of the test plates to an accuracy of at least 0.01mm;
- (e) Miscellaneous Apparatus, including columns, steel shims, and other construction tools and equipment required for preparation of the test pits and loading apparatus. (See Note 1)

### 3. PREPARATION FOR TESTS

- (a) Selection of Test Areas. - The selection of representative test areas to be based on the results of exploratory borings and on the design requirements of the structure;
- (b) Unless otherwise specified, the load test should be made at the elevation of the proposed footings and under the same conditions to which the proposed footings will be subjected, such as confined or unconfined footing, at the moisture conditions as found, or as may be altered by possible future wetting;
- (c) Test Pits. - At least three test locations shall be required, and the distance between test locations shall be not less than three times the diameter of the largest plate used in the tests. Prior to loading, test pits and areas should be protected against moisture changes in the soil unless it is expected that wetting of the soil will occur at some future time, as in the case of hydraulic structures. In this case, the soil in the area should be pre-wetted to the desired extent to a depth not less than twice the diameter of the largest bearing plate;
- (d) Loading Platforms. - The loading platforms or bins shall be supported by cribbing, or other suitable means, at points as far removed from the test area as practicable. The total load required for the test shall be in place before the test is started;
- (e) Dead Load. - All equipment used, such as steel plates, loading column and jack, etc., that are to be placed on the test area prior to the application of load increments, shall be weighed and recorded as dead load.

#### 4. PROCEDURE

- (a) Load Increments. - Apply the load to the soil in increments of not more than  $100\text{kN/m}^2$  or of not more than one-fifth of the estimated bearing capacity of the area being tested. Accurately measure each load;
- (b) and apply it in such a manner that all of the load reaches the soil as a static load, without impact, fluctuation, or eccentricity;
- (c) Time Interval of Loading - After the application of each load increment, maintain the cumulative load with no more than negligible variation for a selected time interval of not less than 1 hour. Other longer time intervals may be determined by maintaining the load until the settlement has ceased or the rate of settlement becomes uniform, but any time interval so selected shall be maintained for each load increment in all tests of any series.

#### 5. RECORD OF TESTS

In addition to the continuous listing of all time, load and settlement data for each test, as prescribed in Section 4, a record shall also be made of all associated conditions and observations pertaining to the test, including the following:

- Date;
- List of Personnel;
- Weather conditions, and;
- Irregularity in routine procedure.

#### **NOTES ON TEST:**

1. Testing assemblies may vary widely, depending on job conditions, testing requirements, and equipment available. The testing assembly and program of testing should be planned in advance and approved by the supervising engineer, and, in general, can permit considerable latitude in details within the specific requirements noted above and outlined in the following test procedure.

A typical assembly for conducting load tests is illustrated in Fig. 1.

2. Measurement of Settlement. - Measure the settlement by dial gauges or other devices that will supply measurements accurate to 0.01mm and keep a continuous record of all settlements. Make settlement measurements as soon as possible before and after the application of each load increment, and at such equal time intervals, while the load is being held constant, as will provide not less than six settlement measurements between load applications. The reference beam supporting the dial gauges or other settlement - recording device shall be independently supported as far from load application as practicable, and preferably not less than 2.5m.
3. Termination of Tests. - Continue each test until the settlement has definitely become progressive and the rate of settlement or load has increased beyond the capacity of the testing apparatus. If sufficient load is available, the test should be continued until the total accumulated settlement is not less than 25mm. After completion of observations for the last load increment, release this applied load in steps and continue recording dial readings until there is no further elastic rebound for a period that is at least equal to the selected time interval. Other loading and unloading sequences may be adopted to suit the particular requirements of the project. These should be agreed before the commencement of the tests.

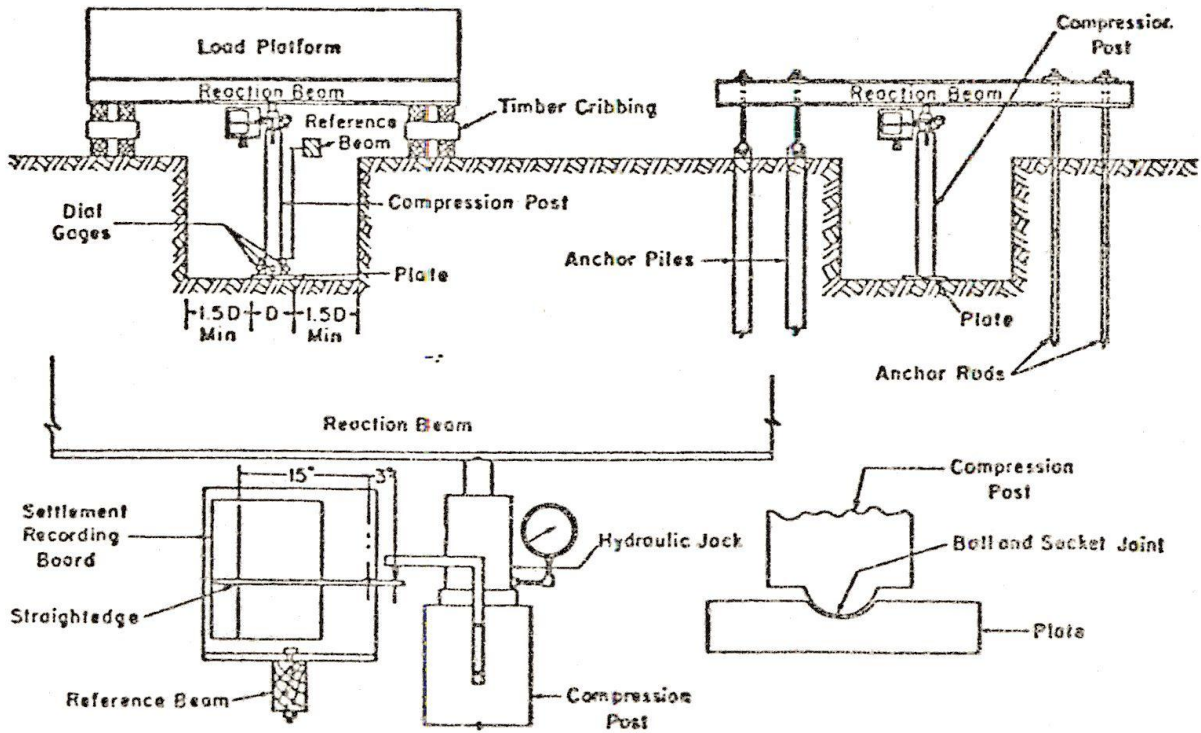

FIG. 1.—Typical Setup for Conducting Static Load Tests.

## STANDARD BALL PENETRATION TEST

### 1. SCOPE

This test method describes the penetration of a road surface, which is to be sealed, by a standard ball under the impact of a standard load, and the measurement of the embedment that takes place. Two alternative methods of measurement of embedment are given]. The results may be used to estimate the likely embedment of sealing aggregate into the road under service conditions.

### 2. APPARATUS

- a) Standard marshal compaction hammer;
- b) 19.0mm steel ball bearing;
- c) Thermometer graduated in c [0-100]c;
- d) Cumulative dial gauge [50mm travel 0.01mm units], or circular tripod with a movable cross-bar and dial gauge [0.01mm units] or vernier callipers.

### 3. PROCEDURES

#### 3.1 Measurement with the cumulative dial gauges:

- i. Select a typical sub-lot representative of the road surface to be sealed;
- ii. Site the standard ball randomly on the sub-lot;
- iii. Rest the base of the compaction hammer on the ball and apply one blow of the falling weight then remove hammer and ball;
- iv. Place the cumulative dial gauge in position and register the depth of the penetration;
- v. Repeat steps (ii) to (iv) on at least ten sites on each sub-lot, and obtain a total accumulated depth of penetration for all sites;
- vi. Divide the total accumulated depth of penetration by the number of sites tested to give the average ball penetration. RECORD;
- vii. Record the temperature of the road surface for each set of readings.

#### 3.2 Measurement using the circular tripod, cross-bar and dial gauge:

- i. as 3.1 (i);
- ii. as 3.1 (ii);
- iii. Place the circular tripod around the ball, so that the foot of the dial gauge or vernier callipers on the cross-bar touches the top ball, and take an initial reading of the gauge to locate the level of the top of the ball. RECORD;
- iv. Remove the cross-bar and dial gauge leaving the circular tripod in place to provide a fixed reference level;
- v. Rest the base of the compaction hammer on the ball and apply one blow of the falling weight;
- vi. Remove the hammer and place the cross-bar and gauge back in position and take a reading of the level of the top of the ball. RECORD;
- vii. Record the difference between the first and second readings as the ball penetration;
- viii. Repeat steps 3.3 (ii) to (vii) at least ten times on each sub-lot and average the result;
- ix. Record the temperature of the road surface for each set of readings.

### 3.3 Temperature correction of the ball penetration of bitumen surfacings

Correct the average ball penetration of bituminous surfacings from the penetration of the surface at the temperature of test to the temperature most prevalent in the summer months using the following formula:

$$\text{Pen } T_s = \text{Pen } T_t - K [T_t - T_s];$$

Where Pen  $T_s$  = penetration depth at standard summer road surface temperature for region [mm];

Pen  $T_t$  = penetration depth at the time of the test [mm];

$T_s$  = Standard temperature of road for region [C];

$T_t$  = temperature of the road surface at the time of test [C];

$K$  = temperature susceptibility of penetration [mm/C] = 0.04mm/C.

## 4. REPORTING

Report the Pen  $T_o$  to the nearest 0.1mm.

TO MODIFY THE TEST METHOD FOR QUICKER RESULTS AND EASIER FIELD WORK YOU CAN:

1. Bronze the ball on the bottom of the marshal hammer;
2. Instead of using the reference ring, datum x-bar and depth gauge, use a tyre tread gauge to measure the indentation that the ball makes.

[This method is much quicker and is just as accurate]

## MEASUREMENT OF LAYER THICKNESS

### 1. SCOPE

This method describes the procedure for the determination of the thickness of fill, subgrade and pavement layers using direct measurement.

### 2. APPARATUS

- (a) Excavation tools, eg auger, pick, scoop;
- (b) Rule or metal tape graduated in millimetres;
- (c) Straightedge to span the hole;
- (d) A pointer. A nail may be used or the pointer may be integral with the rule (optional).

### 3. PROCEDURE

- (a) Select a sample site;
- (b) Excavate a hole to a depth at least 10mm below the lower surface of the layer to be measured. The lower surface may be indicated by a change in texture or colour. The hole dimensions should be such that the sides of the hole can be clearly seen;
- (c) Place the straightedge on the road surface so that it spans the excavated hole (Note 1);
- (d) Measure the distance between the lower edge of the straightedge and the lower surface of the layer (Note 2) to be measured and record the distance. If the layer interface is irregular select a point such that the amount of upper and lower material below and above the point respectively, are approximately equal;
- (e) Where there is only one layer, the distance measured is the layer thickness;
- (f) Where there is more than one layer, repeat Procedure (d) to determine the distance to each layer interface from the lower edge of the straightedge and calculate the layer thicknesses by subtraction.

### 4. REPORTING

- (a) Report the layer thickness for each layer in accordance with Table 1.

**TABLE 1**

FOR LAYER THICKNESS M	REPORT TO NEAREST mm
<0.5	5
0.5 to 1	10
>1	20

- (b) The following information may also be reported:
  - Road Name or Number;
  - Chainage;
  - Transverse Position;
  - Material Type;
  - Date of Test.



**NOTES**

1. The straightedge should be resting on undisturbed surface. Where the process of excavation has disturbed the surface around the hole this material should either be removed or tamped back into position to ensure the straightedge is at the correct level.
2. A pointer may be used to indicate to lower surface of any layer to reduce errors due to parallax.

## SAMPLING AND TESTING OF OVERSIZE MATERIALS (>150mm) FOR PARTICLE SIZE DISTRIBUTION

### 1. SCOPE

This Test Method sets out the procedure for the determination of the Particle Size Distribution of materials which contain particles sizes greater than 150mm. The method is applicable to Soil, Rock, Aggregates and RipRap.

### 2. APPARATUS

- (a) Large Sieves;
- (b) Power Equipment eg. Backhoe, Excavator or Front End Loader;
- (c) Platform Scales;
- (d) Bins and Buckets as applicable;
- (e) Shovels, Brushes;
- (f) Tape Measure;
- (g) A.S. Sieves;
- (h) Templates for 1,000mm, 600mm, 350mm, 300mm, 200mm and 150mm sizes;
- (i) Calibrated Weighbridge;
- (j) Prepared clean, hard, level and durable area suitable as a field work area.

### 3. SAMPLING PROCEDURE

#### 3.1 General Considerations

- i. Sampling shall be carried out with the utmost care and integrity by properly trained personnel.
- ii. Sampling shall be conducted by means which ensure that the samples represent, as far as practicable, the true nature of the main body of material from which they were drawn.

#### 3.2 Sample Size Requirements

A bulk sample of sufficient size is required so that the accidental exclusion or inclusion of a single large particle will not significantly affect the result. The following minimum sample masses are required:

Nominal Maximum Particle Size mm	Minimum Mass of Sample for Sieving kg
150	125
200	250
300	500
350	550
600	1,450
1,000	3,750

### 3.3 Stockpile Sampling Aided by Power Equipment

- (a) Randomly select five (5) increment sample locations from around the stockpile;
- (b) Using power equipment remove one (1) bucketful of material from a fresh exposed face of the stockpile (first increment sample). Place this material in a heap on a clean hard level surface and level the top of the heap;
- (c) For the next sample increment remove one (1) bucketful of material from the next sampling location and place in a heap on top of the first increment point and level the top of the heap. Avoid segregation of the material;
- (d) Repeat Step (c) for the remaining sample increments;
- (e) When all five (5) increment samples are in place, each on top of the previous, use the power equipment to remove a bucket full of material. Discard this bucket full to remove bias associated with possible segregation in constructing the sample heap;
- (f) From the remaining material in the levelled heap obtain a sample of sufficient size (representative of the material under test), to satisfy the requirements specified in Section 3.2.

## 4. TESTING PROCEDURE

- (a) Determine the tare weight of the vehicle that will transport the sample from the source area to the prepared work area at a calibrated weighbridge;
- (b) Retrieve a representative sample from the source area by means of appropriate power equipment;
- (c) Determine the gross weight of the vehicle transporting the sample transporting the sample from the source area to the proposed work area at a calibrated weighbridge;
- (d) Determine the total mass of the sample;
- (e) Transport the sample to the prepared work area or laboratory and place it in a heap;
- (f) Separate the oversize material (>150mm or >200mm), weigh and record the mass of the retained particles for each sieve size given in the applicable job specification. This may be performed using templates of appropriate sizes, e.g. 1,000mm, 600mm, 350mm, 300mm, etc;
- (g) The remaining sample (minus 150mm or 200mm) shall be mixed, levelled and quartered to obtain a sub-sample of minimum mass 125kg for minus 150mm material or 250kg for minus 200mm material. The minus 200mm material may be sieved over a 125mm A.S. sieve to obtain a sub-sample of minimum mass 125kg;
- (h) The sub-sample shall be tested in accordance with AS1289.3.6.1.

## 5. REPORTING

Report in accordance with AS 1289.3.6.1.

### NOTES ON TEST:

1. Ensure that ground level materials do not contaminate samples when obtaining the samples from the stockpiles.
2. Ensure that the sample obtained for testing visually represents the subject stockpile material.
3. If large and unmanageable particles are encountered (i.e. large boulders) these particles shall be re-loaded on to an appropriate vehicle and transported to the calibrated weighbridge as described in Section 4 (a), (c) and (d) above. Alternatively, large boulders may be split up using a sledgehammer, jackhammer or other suitable means, to facilitate weighing. Details of such activity are to be recorded.
4. Photographs should be obtained of the stockpile and test sample for inclusion in the report.

## INDEX OF TEST METHODS

TEST METHOD	SECTION 3 - SAMPLING & TESTING AGGREGATES	PAGE NUMBER
NTTM 302.2	Wet/Dry Cycle - Durability Test. (Minus 100mm size)	2
NTTM 302.3	Wet/Dry Cycle - Durability Test. (Plus 100mm size)	5
NTTM 304.1	Skid Resistance Using the Portable Pendulum Tester.	8
NTTM 305.1	Pavement Surface Texture Depth.	16

## WET DRY CYCLE (DURABILITY) TEST (MINUS 100mm SIZE)

### 1. SCOPE

This method describes the standard laboratory procedure for determining the resistance of rock spalls or aggregate to repeated soaking and drying cycles. It provides information to assist in assessing the soundness of rock spalls or aggregates when used as protection rock, armour rock or riprap subject to exposure and weathering action.

### 2. APPARATUS

- (i) Oven - complying with the requirements of AS 1289.0. Thermostatically controlled to operate at the following temperatures:
  - low temperature 55°C to 60°C
  - high temperature 105°C to 110°C;
- (ii) Sieves - as required, complying with AS 1152;
- (iii) Balance - of adequate capacity, and accuracy of 5g;
- (iv) Metal trays - of suitable capacity to allow the sample to be immersed in testing fluid and covered by a depth of at least 15mm as per Procedure 5(e);
- (v) Sledgehammer - (of suitable weight) or crusher.

### 3. SAMPLING

By AS 1141.3.2 (Sampling of Rock Spalls, Boulders and Drill Core).

### 4. PREPARATION

The sample shall be broken down by sledgehammer to produce approximately 20kg of well graded aggregate passing the 100mm sieve, retained 9.5mm sieve (see Notes 1 and 2).

### 5. PROCEDURE

- (a) Thoroughly wash (with potable water) approximately 20kg of the sample over a 9.5mm sieve. Discard all material passing the 9.5mm sieve. Dry the sample to constant mass at a temperature between 105°C to 110°C;
- (b) Sieve the sample over a 9.5mm sieve, either by hand or mechanical shaker. Discard all material passing the 9.5mm sieve (see Note 3);
- (c) Count and record the number of rock pieces retained on the 9.5mm sieve.
- (d) Weigh and record the dry mass retained on the 9.5mm sieve, (m1) to an accuracy of 5g.
- (e) Place the sample in a metal tray/s and immerse the sample in the testing fluid for 16 to 72 hours (see Note 4). The sample shall be covered by a depth of at least 15mm and kept at room temperature.
- (f) At the end of the immersion period, drain the sample. Place the sample in the low temperature drying oven for 16 to 72 hours.
- (g) Remove the sample from the oven, allow it to cool to room temperature and immerse again in the testing fluid. Repeat the process of alternate immersion and drying until five cycles have been completed.
- (h) Inspect the sample. If significant breakdown has occurred then dry to constant mass at a temperature between 105°C to 110°C(see Note 5). Sieve the sample using a 9.5mm sieve. Weigh and record the mass retained on the 9.5mm sieve (m2). Discard all material passing the 9.5mm sieve.

- (i) Repeat the process of alternate immersion and drying for a further fifteen cycles (i.e. a total of 20 cycles). After each five cycles, inspect the sample for breakdown. If significant breakdown has occurred after any set of five cycles, repeat step (h) (see Note 5).
- (j) At the completion of the test, dry the sample to constant mass at a temperature between 105°C to 110° C, then sieve the sample using a 9.5mm sieve. Weigh and record the mass retained on the 9.5mm sieve (m2). Count and record the number of rock pieces retained on the 9.5mm sieve. Discard all material passing the 9.5mm sieve.

## 6. CALCULATION

The Wet/Dry Durability (WDD) is assessed as the amount of material retained on the 9.5mm sieve expressed as a percentage of the original dry mass at the start of the test.

$$WDD = \frac{m_2 \times 100}{m_1}$$

This calculation is performed for each time the sample mass was determined.

## 7. REPORT

The percent passing (WDD) shall be reported to the nearest 0.1 percent and shall be reported with the number of cycles. Report the WDD for each recorded set of cycles (Procedure 5 (g), (h), (i) & (j)).

## 8. PRECISION

Results obtained by one operator using the same equipment in repeat tests on different samples drawn from a single bulk sample should not vary by more than ten percent.

### NOTES ON METHOD:

1. Care shall be taken when breaking down rock spalls with the sledgehammer not to unduly fracture the material.
2. A well graded aggregate has a continuous distribution of grain sizes from the 100mm size to the 9.5mm size.
3. Sieving may be done by hand or with a mechanical shaker. When sieving by hand, continue sieving until the mass passing the sieve in 1 minute is less than 1 percent of the mass of material retained on the sieve. In the case of mechanical sieving, determine the minimum sieving time by comparison with hand sieving. Do not overload sieves.
4. The testing fluid is usually tap water at room temperature, but may be natural ground water, seawater, a dilute acid with a dispersing agent as appropriate to the anticipated environment of the rock.
5. Significant breakdown is defined (for the purpose of this test) as any flaking, splitting, disintegration or other breakdown of the rock mass or rock substance, that can be visually ascertained and which results in a percent passing the 9.5mm sieve of 2% or more.
6. The test is terminated after a total of twenty cycles, but may be terminated earlier if breakdown is severe, or may be extended beyond twenty cycles if necessary. Severe breakdown is defined (for the purpose of this test) as any flaking, splitting, disintegration or other breakdown of the rock mass or rock substance, that is readily apparent visually and which results in a percentage passing the 9.5mm sieve of 5% or more.
7. Photography of the sample at various stages throughout the test can assist with qualitative assessment and reporting.
8. Information gained from this test shall be used as a guide for determining the acceptability of aggregate for use as protection rock and/or riprap.

**WET DRY CYCLE (DURABILITY) TEST**

PROJECT:

SAMPLE NO:

FEATURE:

MATERIAL TYPE:

Initial Oven Dry Mass (M1) = ..... g

$$WDD = \frac{M2 \times 100}{M1}$$

Progressive Oven Dry Mass (M2)

Cycle No.	Immersion Date		Low Temp Oven Date		No. of Rock Pieces	
	In	Out	In	Out	Commencement	Completion
1					m2 =	
2						
3						
4						WDD @ 5 CYC. = _____%
5						
6					m2 =	
7						
8						
9						WDD @ 10 CYL. = _____%
10						
11					m2 =	
12						
13						
14						WDD @ 15 CYL. = _____%
15						
16					m2 =	
17						
18						
19						WDD @ 20 CYL = _____%
20						
21					m2 =	
22						
23						
24						WDD @ 25 CYL = _____%
25						
26					m2 =	
27						
28						
29						WDD @ 30 CYL = _____%
30						

## WET DRY CYCLE (DURABILITY) TEST (PLUS 100mm SIZE)

### 1. SCOPE

This method describes the standard laboratory procedure for determining the resistance of rock spalls of size 100-300mm, to repeated soaking and drying cycles. It provides information to assist in assessing the soundness of rock spalls when used as protection rock, armour rock or riprap subject to exposure and weathering action.

### 2. APPARATUS

- (i) Oven - complying with the requirements of AS 1289.0. Thermostatically controlled to operate at the following temperatures:
  - low temperature 55° C to 60° C
  - high temperature 105° C to 110° C
- (ii) Sieves - as required, complying with AS 1152
- (iii) Balance - of adequate capacity, and accuracy of 5g
- (iv) Metal trays or water bath of suitable capacity to allow the rock spalls to be immersed in the testing fluid and covered by a depth of at least 30mm, as per Procedure 5(b).
- (v) Sledgehammer - of suitable weight.

### 3. SAMPLING

By AS 1141.3.2 (Sampling of Rock Spalls, Boulders and Drill Core). In particular note the following: "Sampling shall be carried out with the utmost of care and integrity by properly trained personnel, otherwise test results obtained from the samples may misrepresent the characteristics of the material." All sampling shall be done by the testing laboratory. "Sampling shall be conducted by means which ensure that the samples represent, as far as practicable, the true nature of the main body of material from which they were drawn."

Visually assess the rock spalls in the stockpile to be sampled and evaluate the strength and other characteristics of the rock spalls with a hammer or other means. From this evaluation, select 5 to 8 representative spalls of the rock in the size range 100mm to 300mm (weight 25 to 40kg) that can be handled without undue difficulty. If necessary these may need to be obtained by breaking larger stones with a sledgehammer (see Note 1).

### 4. PREPARATION

- (a) Thoroughly wash the sample and scrub with a wire brush until clean, using potable water. Dry the sample to constant mass at a temperature between 105°C to 110°C.
- (b) Number each rock spall with paint or other indelible mark.
- (c) Photograph each rock spall sufficiently to enable any subsequent breakdown to be visually discerned (see Note 5).



## 5. PROCEDURE

- (a) Weigh and record the dry mass of each rock spall to an accuracy of 5g. The combined mass of all rock spalls shall be recorded. Label each rock spall and photograph.
- (b) Place the rock spalls in a metal tray/s or water bath and immerse the spalls with the testing fluid for 16 to 48 hours (see Note 2). The spalls shall be covered by a depth of at least 30mm and kept at room temperature.
- (c) At the end of the immersion period, drain the rock spalls for at least 10 minutes and/or towel dry the excess fluid until the rock spalls attain the saturated surface dry condition. Place the rock spalls in the low temperature drying oven for 8 to 48 hours.
- (d) Remove the rock spalls from the oven and immediately immerse them again in the testing fluid.
- (e) Repeat the process of alternate immersion and drying until five cycles have been completed.
- (f) Inspect the sample. If nil or insignificant breakdown has occurred, then proceed to step (g). If significant breakdown has occurred, (see Note 3) then dry to constant mass at a temperature between 105° C to 110° C. Sieve each rock spall on the 75mm sieve. Weigh and record the mass of each rock spall. Record the combined mass of all rock spalls retained on the 75mm sieve. Retain for future inspection all material passing the 75mm sieve. Photograph if appropriate (see Note 5).
- (g) Repeat the process of alternate immersion and drying for a further fifteen cycles (i.e. a total of 20 cycles). After each five cycles, inspect the sample for breakdown. If significant breakdown has occurred after any set of five cycles, repeat step (f).
- (h) At the completion of the test (see Note 4), dry the sample to constant mass at a temperature between 105° C to 110° C, then sieve the sample using a 75mm sieve. Weigh and record the mass of each rock spall. Record the combined mass of all rock spalls retained on the 75mm sieve. Retain for inspection all material passing the 75mm sieve. Photograph the rock spalls and the material passing the 75mm sieve. Describe the condition of each rock spall in terms of flaking, splitting, disintegration or other breakdown of the rock mass and rock substance.

## 6. CALCULATION

Calculate the percentage loss of material for each rock spall and the total sample each time significant breakdown occurred and the sample mass was determined (steps (e) and (g)).

## 7. REPORT

Provide a qualitative and quantitative assessment of the durability of the rock in relation to the proposed use of the rock. Describe the condition of each rock spall in terms of flaking, splitting, disintegration or other breakdown of the rock mass and rock substance. Report the percentage loss for each rock spall and the total sample each time significant breakdown occurred and the sample mass was determined. The percent passing shall be reported to the nearest 0.1 percent and shall be reported with the number of cycles. The dates of the start and completion of the test shall be reported. Initial and final masses of all rock spalls shall be reported. All photographs shall be supplied. Report all test conditions.

**NOTES ON METHOD:**

1. Care shall be taken when breaking down rock spalls with the sledgehammer not to unduly fracture the material.
2. The testing fluid is usually tap water at room temperature, but may be natural ground water, seawater, a dilute acid or a dispersing agent as appropriate to the anticipated environment of the rock.
3. Significant breakdown is defined (for the purpose of this test) as any flaking, splitting, disintegration or other breakdown of the rock mass or rock substance, that can be visually ascertained and which results in a percent passing the 75 mm sieve of 2% or more after 5 cycles.
4. The test is terminated after a total of twenty cycles, but may be terminated earlier if breakdown is severe, or may be extended beyond twenty cycles if considered necessary, for example if breakdown is only just starting to appear. Severe breakdown is defined (for the purpose of this test) as any flaking, splitting, disintegration or other breakdown of the rock mass or rock substance, that is readily apparent visually and which results in a percentage passing the 75mm sieve of 5% or more after 5 cycles.
5. Photography of the sample at various stages throughout the test is aimed at assisting the qualitative assessment and reporting.
6. Information gained from this test shall be used as a guide for determining the acceptability of rock spalls for use as protection rock, armour rock or riprap.

## DETERMINATION OF SKID RESISTANCE WITH THE PORTABLE SKID TESTER

### 1. SCOPE

This method describes the procedure for determining the skid resistance value of a surface. The test is performed on sealed driving surfaces, under wet conditions.

### 2. DEFINITION

The skid resistance value of a surface is a measure of the frictional resistance between a rubber slider and the test surfaces.

### 3. APPARATUS

#### (i) Pendulum Friction Tester

A tester and auxiliary scale constructed in accordance with details available from the Australian Road Research Board, Melbourne (see Figure 1). All bearings and working parts of the instrument shall be enclosed as far as possible, and all materials used shall be suitably treated to prevent corrosion under wet conditions.

The tester shall be used and stored in a dust free environment and one which is not subject to a large temperature variation.

The pendulum friction tester shall be calibrated to ensure compliance with the following requirements at intervals not exceeding 2 years or when results obtained from the friction tester control specimens vary from the established values by more than 3 units (see Note 1).

The tester shall incorporate the following:

- (i) A spring loaded rubber slider of the properties specified in Clause 3 (b) mounted on the end of a pendulum arm so that the sliding edge is  $515 \pm 2$ mm from the axis of suspension.
- (ii) Means for levelling the instrument.
- (iii) Means for raising and lowering the axis of suspension of the pendulum so that the slider can:
  - swing clear of the surface of the specimen; and
  - be set to slide over a fixed length of surface
- (iv) Means for holding and releasing the pendulum arm so that it falls freely from a horizontal position.
- (v) A pointer balanced about the axis of suspension, indicating the position of the pendulum arm throughout its forward swing and moving over the circular scale attached to the instrument. The mass of the pointer, excluding felt friction washers, shall be not more than 85g and the friction in the pointer mechanism shall be adjustable so that, with the pendulum arm swinging freely from a horizontal position, the outward tip of the pointer may be brought to rest on the forward swing of the arm at a point 10mm below the horizontal, the point corresponding to the zero position on the attached circular scale.

The mass of the swinging arm including the slider shall be  $1.5 \pm 0.03$ kg with the centre of gravity lying on the axis of the arm at a distance of  $410 \pm 5$ mm from the centre of suspension.

The slider shall be mounted on an axis set at an angle of  $25^{\circ} \pm 1^{\circ}$  to the horizontal when the pendulum is at the lowest point of its swing, so that only the rear edge of the slider contacts the test surface. The slider can turn about its axis without obstruction to follow unevenness of the surface.

The slider shall be spring loaded against the test surface and the nominal static force on the slider is set by the calibration procedure (see Note 1).

**NOTE 1:** Calibration of the friction tester is available through the Australian Road Research Board, Melbourne. Alternatively, calibration may be arranged through local laboratories having NATA certification for calibration of friction testers.

(j) Rubber Sliders

Rubber sliders used in the friction tester shall be  $24 \pm 1$ mm deep and  $6 \pm 1$ mm thick and rigidly backed. The sliding edges shall be square, clean cut and free from contamination. Avoid handling the surfaces of sliders at all times.

The rubber used in the sliders shall comply with the requirements given in Table 1.

When not in use, sliders shall be stored in the dark at a temperature between  $10^{\circ}\text{C}$  and  $25^{\circ}\text{C}$ . They shall be discarded when:

- they are more than 12 months old from the date stamped on the slider; or
- they do not comply with the requirements of Table 1; or
- the two available edges of the slider have each become rounded.

**TABLE 1**  
**PROPERTIES OF SLIDER RUBBER**

Property	Temperature				
Resilience, percent*	0	10	20	30	40
Hardness IRHD†	44 to 49	58 to 65	66 to 73	71 to 77	74 to 79
	55±5	55±5	55±5	55±5	55±5

\* Lupke rebound test in accordance with BS 903: Part A8

† International rubber hardness degrees in accordance with BS 903: Part A26

**NOTE 2:** Rubber sliders complying with this standard are available through the Australian Road Research Board, Melbourne

(k) Water Spray Bottle

Water spray bottle containing clean potable water at ambient temperature.

(l) Thermometer

The thermometer shall have a range of  $0^{\circ}\text{C}$  to  $50^{\circ}\text{C}$  in accordance with AS 1141.2.

(m) Supply of distilled or potable water.

**4. PREPARATION OF TEST SURFACE**

- (a) Inspect the road and visually choose representative section(s) to be tested
- (b) Ensure that the test surface is free from loose grit and other debris by washing clean with water.

**5. SETTING THE TESTER**

- a) Set the base level by means of the spirit level and three levelling screws on the base frame (Note 4).
- b) Raise the head so that the pendulum arm swings clear of the surface (Note 3).

**NOTE 3:** Movement of the head of the tester (carrying the swinging arm, graduated scale, pointer and release mechanism) is controlled by a rack and pinion on the rear of the vertical column. After unclamping the locking knob A at the rear of the column, the head may be raised or lowered by turning either of the two knobs B. When the required height is obtained, the head unit must be locked in position again by clamping knob A.

**NOTE 4:** Ensure that the feet on the levelling screws are adjusted correctly, to prevent the levelling screws from indenting the bitumen seal in hot conditions.

**6. CALIBRATION OF EQUIPMENT**

- (c) Checking the zero setting as described in Note 5.

**NOTE 5:** This is done by first raising the swinging arm to the horizontal release position, on the right hand side of the apparatus. In this position it is automatically locked in the release catch. The pointer is then brought round to its stop, in line with the pendulum arm.

The pendulum arm is released by pressing button C. The pointer is carried with the pendulum arm on the forward swing only. Catch the pendulum arm on its return swing, and note the pointer reading. Return the arm to the release position.

- (d) Correct the zero setting as necessary by adjustment of the friction rings E. (see Note 6).

**NOTE 6:** If the pointer has swung past the zero position rings E are screwed up a little more tightly. If it has not reached zero the rings should be unscrewed a little.

This adjustment is necessary as the tester may be used under different temperature conditions and in windy conditions: sufficient adjustment has been allowed to cover all normal ranges of temperatures encountered, but some difficulty may be experienced in correcting the zero in very high winds - it may be necessary to operate the tester with a wind shield.

**7. PROCEDURE**

- (a) With the pendulum arm free, and hanging vertically, place the sliding spacer under the lifting handle setting-screw to raise the slider.
- (b) Lower the head of the tester using knobs A & B so that the slider just touches the road surface, and clamp in position with knob A.
- (c) Remove the spacer.

- (d) Check the sliding length of the rubber slider over the surface under test, by gently lowering the pendulum arm until the slider just touches the surface on one side and then on the other side of the vertical.

**NOTE 7:** The sliding length is the distance between the two points where the sliding edge of the rubber touches the test surface.

To prevent undue wear of the slider when moving the pendulum arm through the arc of contact, the slider should be raised off the road surface by means of the lifting handle.

- (e) If necessary, adjust to the correct length by raising or lowering the head slightly.

**NOTE 8:** When the apparatus is set correctly the sliding length should be between 12.4 and 12.7cm on the scale provided, (the outer marks are 12.7 cm apart and the inner ones are 12.4cm apart).

- (f) Place the pendulum arm in its release position.  
 (g) The apparatus is now set for the test operation

## 8. OPERATION OF THE TESTER

- (a) Wet the road surface and slider ensuring that the road surface is free from loose grit or other debris.  
 (b) Bring the pointer round to its stop.  
 (c) Release the pendulum arm by pressing button 'C' and catch it on the return swing before the slider strikes the road surface.  
 (d) Note the reading indicated by the pointer.

**NOTE 9:** If the slider is not wetted as well as the road surface the reading obtained on this first swing should be discarded.

- (e) Return the arm and pointer to the release position, keeping the slider clear of the road surface in this operation by means of the lifting handle.  
 (f) Operate the pendulum and pointer for five swings, rewetting the test surface and slider before each swing. Read and record the value from each swing.  
 (g) Record the mean of five successive readings, provided they do not differ by more than 3 units.  
 (h) If the range is greater than this, repeat swings until three successive readings do not differ by more than 3 units.  
 (i) Successive swings of the pendulum should always show the same or a lower friction value. If the second, third, fourth or fifth swing shows a higher value than any of the preceding values, a fault is indicated and must be rectified before proceeding. Usually the fault is an increased contact length between slider and surface, check the contact length and reset if necessary.  
 (j) Average the values obtained in 8(f), 8(g), or 8(h) and record the average as the skid resistance value uncorrected for temperature (SRVt).

**9. PROCEDURE WHEN TESTING ROAD SURFACES**

- (a) Inspect the road and visually choose a representative section to be tested.
- (b) Set the apparatus on the road surface in the track chosen to be tested, so that the slider swings in the direction of the traffic.
- (c) Take the mean of five readings, as above, at each location in the test track spaced at approximately 10 metres along the length under test.
- (d) The mean of these readings gives a representative value of skidding resistance of the section of the road.

**NOTE 10:** If the leading edge of the rubber slider becomes worn or rounded, rotate the rubber slider and use the other side. Once both edges of the rubber slider are worn or rounded, discard the rubber slider.

**10. RECORDING OF DATA**

Record the temperature ( $t^{\circ}\text{C}$ ) of the water lying on the road immediately after the test (Note 11).

**NOTE 11:** Investigations have shown that rubber resilience is temperature dependent and changes in rubber resilience will effect the skid resistance measurements: skid resistance tends to fall as temperature rises.

The correction equation to obtain  $\text{SRV}_{40}$  based on surface temperature measurement is:

$$\text{SRV}_{40} = \frac{\text{SRV } t}{1 - 0.00525 (t-40)}$$

**NOTE 12:** The correction procedure in most common use and shown in Road Research Laboratory Road Note 27, 1969 is not suitable for Australian conditions.

**11. MAINTENANCE OF EQUIPMENT**

- (a) At the completion of testing remove the rubber slider and wrap in tissue paper and place in a plastic bag. Store in a cool dark environment at 10 to 25 degrees C.
- (b) If the rubber slider has not been used for more than 4 weeks, the slider shall be given a few swings on a dry surface to clean and liven up the surface of the rubber prior to any testing.

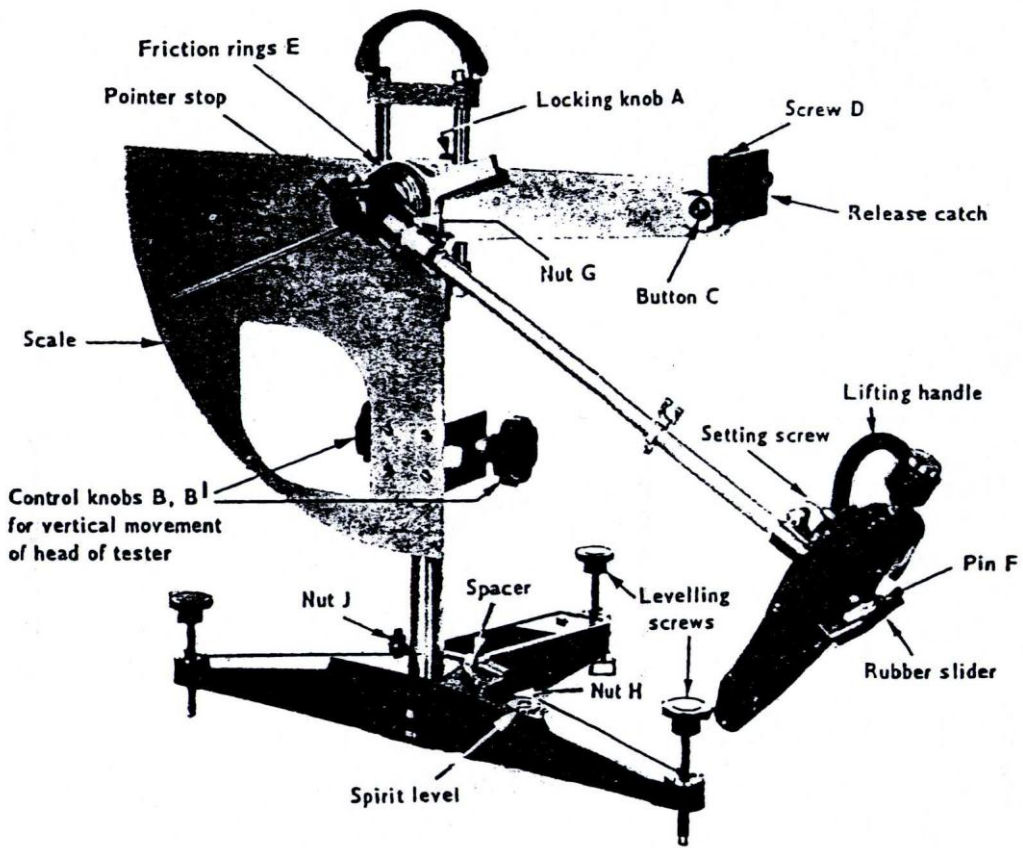



**FIGURE 2 - PORTABLE SKID RESISTANCE TESTER**

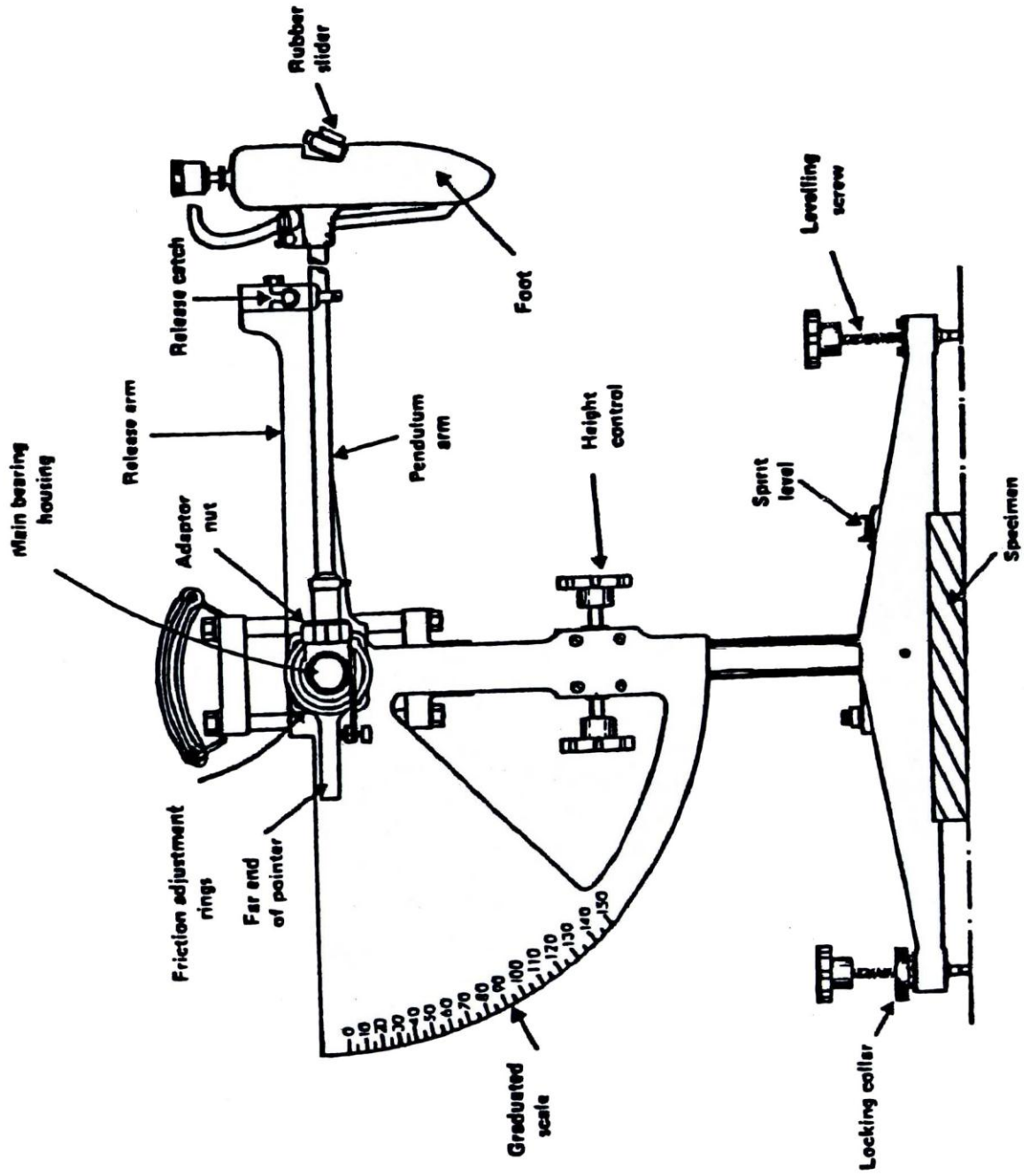

**TABLE 2**

Suggested values of skid resistance for use with the portable tester.

Category	Type	Skid Resistance on Wet Surface	Standard of Skidding Resistance Represented
A	<i>Difficult sites</i> , such as roundabouts; bends with radius less than 500 ft on derestricted roads; gradients, 1 in 20 or steeper and of length greater than 100 yd; approaches to traffic lights on derestricted roads.	Above 65	'Good': fulfilling the requirements even of fast traffic and making it most unlikely that the road will be the scene of repeated skidding accidents.
B*	General requirements, i.e. roads and conditions not covered by categories A and C.	Above 55	Generally satisfactory: meeting all but the most difficult conditions encountered on the roads.
C*	Easy sites, for example, straight roads, with easy gradients and curves, and without junctions, and free from any features such as mixed traffic, especially liable to create conditions of emergency.	Above 45	'Satisfactory only in favourable circumstances'
D	All sites.	Below 45	'Potentially slippery'

\* On smooth looking or fine-textured roads in these categories vehicles having smooth tyres may not find the 'skid-resistance' adequate. For such roads accident studies should also be made, i.e. ensure that there are no indications of difficulties arising from skidding under wet conditions.

## DETERMINATION OF PAVEMENT SURFACE TEXTURE DEPTH SAND PATCH METHOD

### 1. SCOPE OF METHOD

This test method details the Sand Patch method of test for determining the surface texture depths of Portland cement concrete, bituminous concrete and bituminous sealed pavements.

### 2. LIMITATIONS

The Sand Patch test should not be undertaken under adverse conditions such as exist when pavements are wet, or the strength of the wind is sufficient to disturb the sand particles used during the test. The use of a suitable wind screen may provide sufficient shelter to allow the test to be carried out under windy conditions.

### 3. APPARATUS

- (a) A metal cylinder of 100 mm internal depth and 20 mm internal diameter.
- (b) A flat wooden disc 65mm diameter with a hard rubber disc 2 mm thick attached to one face, the reverse face being provided with a handle.
- (c) Dry natural sand or glass beads with rounded particle shape and which will pass a 0.3mm sieve and be retained on a 0.15mm sieve.

### 4. PROCEDURE

- (a) Dry the surface to be measured and sweep clean with a soft brush.
- (b) Fill the cylinder with sand, tapping the base three (3) times on the surface to ensure compaction, and strike off the sand level with the top of the cylinder.
- (c) Carefully pour the sand into a conical heap on the surface to be tested.
- (d) Holding the handle of the wooden disc between the thumb and fore finger, and without applying vertical pressure on the disc, spread the sand in a spiral motion from the centre of the heap so that the sand is spread into a circular patch. Care must be taken to maintain the face of the disc horizontal at all times.
- (e) Continue to spread the sand using a spiral motion to maintain a circular patch until the surface depressions are filled with sand to the level of the surface peaks.
- (f) Measure the diameter of the circular patch to the nearest 5mm at four (4) equally spaced locations, and average the results.

### 5. CALCULATION

Calculate the surface texture depth of the pavement using the formula

$$\text{Surface Texture Depth} = \frac{40,000}{d^2} \text{ mm}$$

Where d is the average diameter of the patch in millimetres.

### 6. REPORT

Report the surface texture depth to the nearest one-hundredth of a millimetre.

## INDEX OF TEST METHODS

TEST METHOD	SECTION 4 - SAMPLING & TESTING PAVEMENT MARKING AND TRAFFIC CONTROL DEVICES	PAGE NUMBER
NTTM 401.1	Wet Film Thickness Comb	2
NTTM 402.1	Measurement of Rate of Application of Spherical Glass Beads	3
NTTM 403.1	Plastic Guide Posts - Vertical Deflection and Angular Deviation	5
NTTM 404.1	Retro-reflectivity Testing of Pavement Marking	8
NTTM 404.3	Retro-reflectivity Testing of Pavement Marking – Wet Condition	13
NTTM 405.1	Certification of Pavement Line Marking Apparatus	14

## MEASUREMENT OF FILM THICKNESS OF ROADMARKING PAINT

### 1. SCOPE

This test method set out the procedure for measuring Wet Film Thickness (WFT) of road marking paint, which has been applied by vehicle mounted spray equipment. Dry Film Thickness may be calculated from the Wet Film Thickness measurement.

**Note 1:** The WFT comb gauge may be used for measuring the Wet Film Thickness of paint films applied by other methods.

**Note 2:** Dry Film Thickness may be determined by multiplying the comb gauge reading by the percent volume solids of the paint. The percent volume solids of the paint is the non-volatile component of the paint.

### 2. EQUIPMENT

- (a) Wet Film Thickness comb gauge with measuring range 50µm to 800µm;
- (b) Metal test panel 100mm x 200mm (approx.).

### 3. PROCEDURE

- (a) Place the test panel in the path of the paint application equipment;
- (b) Record the speed of the line marking equipment as it applies the paint to the test panel;
- (c) Place the gauge carefully and vertically into the wet film immediately it has been sprayed or applied onto the metal test panel;
- (d) Hold the gauge firmly for 5-10 seconds in the wet film and then withdraw it vertically;
- (e) Determine which of the prongs have been covered with paint or thermoplastic material. For correct Wet Film Thickness the material must touch the prong of the gauge marked with the specified thickness but must not touch the prong marked with the next higher thickness;
- (f) The Wet Film Thickness is read from the highest value prong covered by paint adjacent to the next highest value prong which is clean;
- (g) Quickly repeat the measurement at a second location on the panel.

### 3. REPORTING

- (a) Report the average Wet Film Thickness in microns or, if required, the Dry Film Thickness;

$$\text{Dry Film Thickness} = \frac{\text{WFT} \times \text{Paint Percent Volume Solids}}{100}$$

- (b) Report the speed of the application equipment;
- (c) Report the brand and model number of the gauge used.

## MEASUREMENT OF RATE OF APPLICATION OF SPHERICAL GLASS BEADS

### 1. SCOPE

This test gives a procedure for field measurement of the rate of application of spherical glass beads on to wet paint or thermoplastic surfaces.

### 2. EQUIPMENT

- (a) Plastic bag or tray of at least 2 litre capacity;
- (b) Plastic measuring cylinder of 500mL capacity.

### 3. PROCEDURE

- (a) Turn off the paint or thermoplastic supply valves and operate the bead dispenser for exactly 10 seconds allowing beads to run into a plastic bag or tray;
- (b) Pour the beads from the bag or tray into a suitable measuring cylinder calibrated in millilitres to measure the volume of beads collected. Level the beads in the cylinder but do not compact.

### 4. CALCULATION

Figure 1 shows the correct volumes of glass beads required to give net application rates on the marked line of approximately 0.3 kilograms per square meter for different line widths and road speeds. The glass bead volume figures given in Figure 1 are calculated for an actual application rate of 0.34 kilograms per square meter. These figures are used for calibrating the machine because there is a loss of beads between the bead dispenser and the marked line and the volume is measured with beads not compacted.

### 5. REPORTING

Report the volume of beads collected over a ten second period.

**NOTE:** When two or more bead dispensers are to be used each dispenser should be checked separately to make up the totals shown.

FIGURE 1  
SPECIFIED VOLUME OF GLASS BEADS

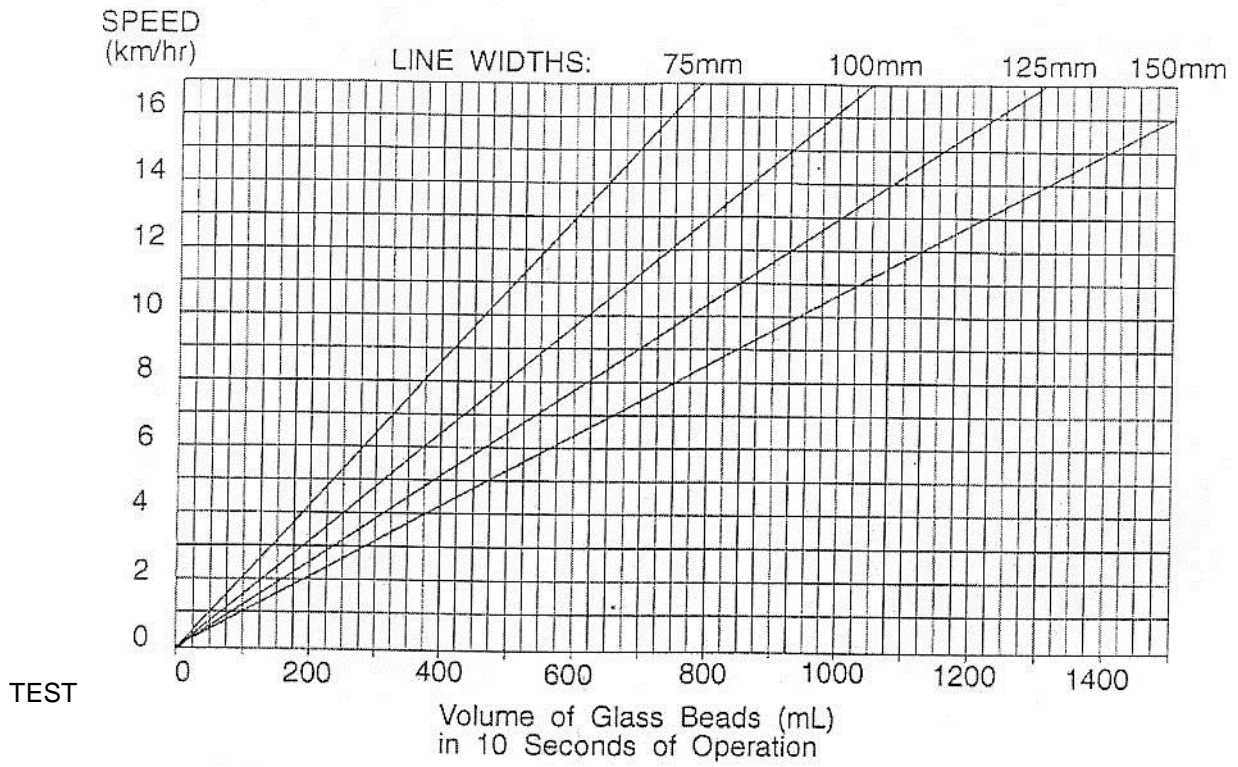

## PLASTIC GUIDE POSTS - VERTICAL DEFLECTION AND ANGULAR DEVIATION

### 1. SCOPE OF METHOD

This test method is in two parts: Part A sets out procedures for testing plastic guide posts for vertical deflection. Part B sets out procedures for measuring angular deviation.

### 2. APPLICATION

The method is applicable to seven different shapes of plastic guide posts, all of which should have a trough shaped cross section. No prior preparation of the guide post is required for either test.

### 3. PRINCIPAL

In Part A the guide post is tested for vertical deflection. Maximum deflection shall not exceed 90 mm to be within acceptance limits.

In Part B the guide post is subjected to an angular twist. The angle measured shall not exceed 45° for the guide post to be within acceptance limits.

Both tests are non-destructive static tests.

### 4. APPARATUS

(a) **A heavy timber base** 1000mm x 230mm x 210mm. (The DPI Base is made up of 5 timber planks each measuring 1000mm x 235mm x 40mm, held together by wood screws). This provides a stable base and the required counter balance for testing 5 guide posts at the same time;

(b) **Five clamps** for attaching guide posts to the base;

These clamps are made from sheet metal; each clamp being individually bent to shape to suit each guide post design, and are 160mm in length. A rubber lining glued to the underside of each clamp ensures a firm grip on the guide post during testing.

The clamps are attached to the base using 7mm bolts provided with wing nuts for tightening of clamps.

(c) **Loading weights and brackets;**

For Test A, a 750g load is applied at a distance of 850 mm from the edge of the clamp. The load is made up of a lead weight machined down to the required mass, i.e. total load = mass of lead weight + mass of bracket.

The lead weight is made from pouring molten lead into a mould 15 mm high by approximately 65mm diameter. A threaded bolt for attaching the lead weight to the bracket is placed in position at the centre of the mould before pouring.

Brackets are made from 12mm x 12mm aluminium channel section. Due to small differences in shapes of individual guide posts, three sizes of brackets with matching weights are required for ease of fitting and removal, the brackets are spring loaded. Wing nuts are used for tightening the brackets to the guide posts;



- (d) Three separate brackets, made of light gauge aluminium channel section are required to suit the assortment of guide posts.

A 600g mass is attached at one end of the guide post. This transfers a torsionally applied load at a distance of 350mm to the free end of the guide post. This lead weight is interchangeable with each of the three brackets.

## 5. PROCEDURE - TEST A: MEASUREMENT OF VERTICAL DEFLECTION

- (a) The guide post selected for testing shall be placed horizontally in the appropriate clamp on the base;
- (b) The distance from the upper end of the guide post to the edge of the clamp shall be set at 900 mm and the guide post shall then be clamped firmly down onto the base, in position for testing;
- (c) A mass of 750g shall be secured to the guide post at a distance of 850 mm from the edge of the clamp;
- (d) Using a suitable rule graduated in millimetres and the floor or suitable bench as a datum, vertical deflection is measured from the centreline of the guide post, and reported to the nearest mm.

## 6. PROCEDURE - TEST B: MEASUREMENT OF ANGULAR DEVIATION

- (a) The guide post shall be clamped in a horizontal position at a distance of 900 mm from its upper end as in Test A;
- (b) A load of 600 g shall be attached to the bracket provided for this test, at 350mm from centreline of guide post to centre of load. The bracket shall then be attached to the guide post at 90° to its centreline (see Fig.3);

The 600g load shall then be released and the angle of deviation measured relative to the horizontal plane using the bench top or floor as a datum;

- (c) A setsquare shall be used in measuring the angle of deviation, and the angle measured reported as being either greater than or less than 45°.

## 7. REPORTING OF RESULTS

- (a) Manufacturers or suppliers name;
- (b) Date of Test;
- (c) Summary of Test Results;
- (d) Reference to Test Method NTTM 403.1.

### TEST A

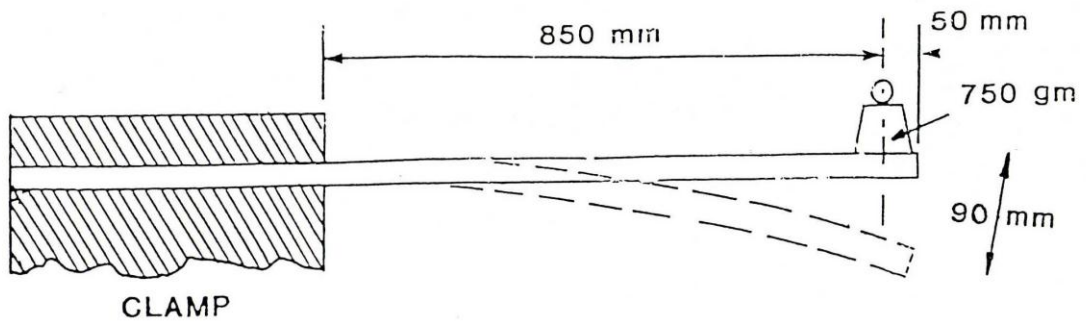

### TEST B

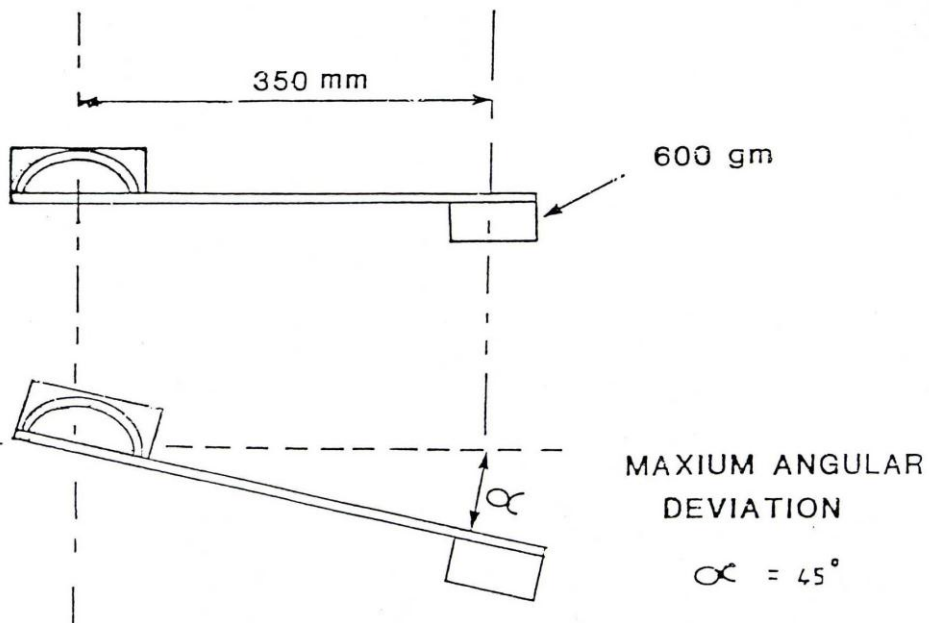
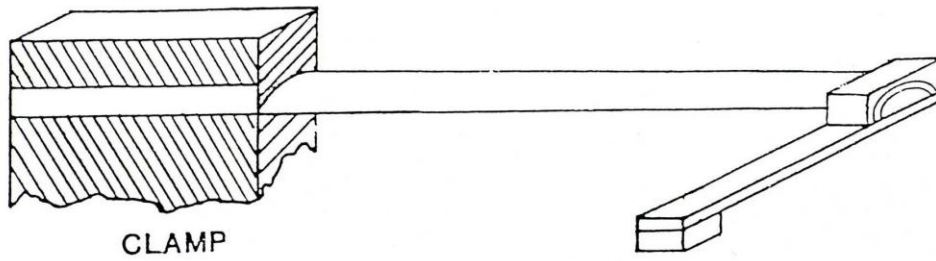

## RETROREFLECTIVITY TESTING OF PAVEMENT MARKING

### 1. SCOPE

This procedure describes the method for determining the retroreflectivity (night visibility) of road markings.

### 2. APPARATUS

- (a) Mirolux Reflectometer and Associated Equipment;
- (b) Global Positioning System (GPS);
- (c) Suitable traffic control system.

### 3. STANDARD TEST SECTION LENGTH

FIGURE 1: STANDARD TEST SECTION LENGTH

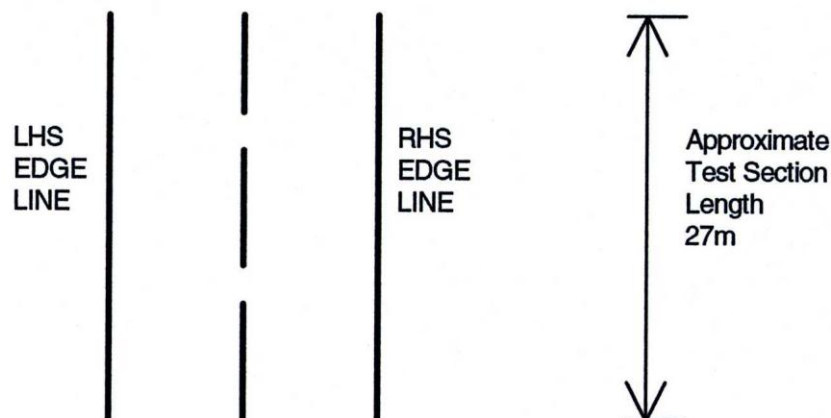

Standard test site length is equivalent to 3 broken centre lines, as shown, approximately 27m.

### 4. SITE SELECTION

Selection of the test site shall be conducted as follows:

- (a) randomly select the first test site;
- (b) further test sites shall be selected at 10km intervals;
- (c) test every **10km** test site;
- (d) test all lines over the length of the test site; and
- (e) where no broken line exists conduct testing on unbroken lines over the equivalent distance for the standard test site.

## 5. PREPARATION

- (a) Turn the instrument on and turn the lamp on. Warm up the instrument for 5 minutes;
- (b) Ensure that the battery reading is greater than 115. A reading less than this will indicate the battery is low and testing should be abandoned;
- (c) Turn the lamp off and adjust the left-hand potentiometer to zero. Ensure the black knob on the rear of the compartment is fully pushed in;
- (d) Turn the lamp on and adjust the right hand potentiometer to the calibration figure for the instrument;
- (e) Recheck the zero as described above in step (c), and then recheck the calibration figure as described above in step (d). Continue to recheck these figures until both the calibration constant and zero figures read correctly;
- (f) Conduct a test on the calibration panel and ensure that the reading displayed is between the limits specified on the calibration panel. If the reading is outside of the specified limits the test should be abandoned;
- (g) The calibration must be checked prior to measuring each test line. A variation of 5 units or more from one line to the next will indicate a low battery level.

## 6. TESTING

- (a) Conduct 6 tests on each broken line in one direction (total 18 tests). Record all these results and determine the average reading for each broken line;
- (b) Conduct 6 tests on each broken line in the opposite direction (total 18 tests). Record all these results and determine the average reading for each broken line;
- (c) LHS edge line: Conduct 10 tests over the equivalent distance of 3 broken lines (27m), in the direction of traffic flow. Record all these results and determine the average reading for the LHS edge line;
- (d) RHS edge line: Conduct 10 tests over the equivalent distance of 3 broken lines (27m), in the direction of traffic flow. Record all these results and determine the average reading for the RHS edge line;
- (e) Take a GPS reading at the site;
- (f) Record the chainage (relative to the nearest DPI 'Permanent Reference Point'), location and line being tested, including the direction of test;
- (g) Draw the locations of the testing on a sketch or plan of the site;
- (h) Repeat test any obvious outliers.

FIGURE 2: EXAMPLE OF TEST PROCEDURE

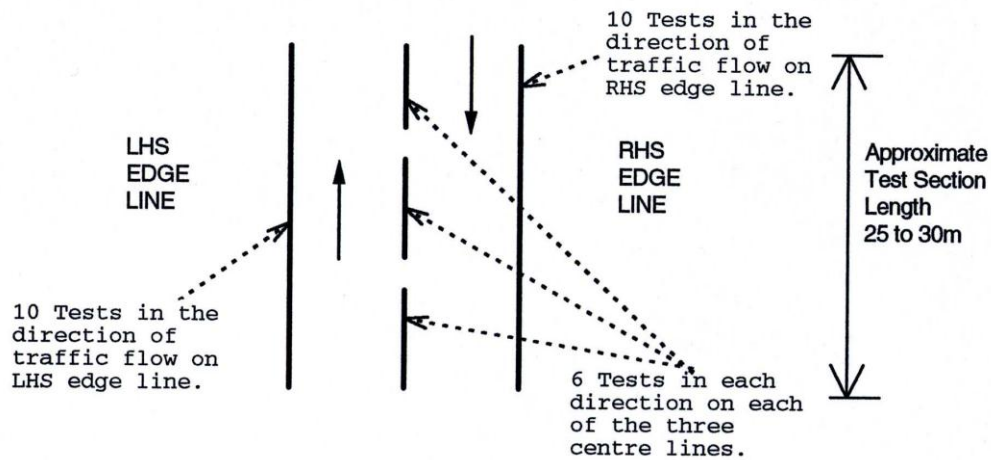

## 7. CALCULATIONS

Determine the average of the test results for each line in each direction.

## 8. REPORTING

Report the following information:

- (a) All test results;
- (b) The averages for each test line in each test direction;
- (c) Test locations;
- (d) GPS co-ordinate of each section, and chainage;
- (e) Sketch of each test site;
- (f) Reflectometer gauge number and calibration constant;
- (g) Date of test;
- (h) Time of test;
- (i) Seal description;
- (j) Paint type;
- (k) Glass bead type/size;
- (l) Date of paint application;
- (m) Testing company;
- (n) Contractor;
- (o) Line marking company, and;
- (p) Direction of test;
- (q) Calibration plate retro-reflectivity range, and;
- (r) Calibration check result.

**NOTES ON TEST:**

1. Where the centre line consists of 2 lines, test the LHS line in the direction of traffic flow, and test the RHS line in the direction of traffic flow, i.e. test one line in each direction;
2. Where turning lines or other lines are marked within the length of the test section conduct a minimum of 10 tests on each of these additional lines over the distance of the standard test section;
3. Where double lines are marked conduct a minimum of 10 tests on each line in the direction of traffic;
4. Where chevrons or other markings appear within the test section, conduct sufficient testing on the markings in the direction of traffic flow;
5. The amount of calibration carried out during the testing depends upon the ability of the instrument to remain charged and retain its calibration, and the speed of the operation.

**RETROREFLECTIVITY TESTING**

**PROJECT:** ..... **REFLECTOMETER NO.:** ..... **DATE OF TEST:** .....

**LOCATION:** ..... **CALIBRATION CONSTANT:** ..... **DATE OF APPLICATION:** .....

**CHAINAGE:** ..... **CALIBRATION PLATE RANGE:** ..... **LINE MARKING CONTRACTOR:** .....

**GPS READING:** ..... **CALIBRATION CHECK VALUE:** ..... **CONTRACTOR:** .....

TEST NO.	LHS EDGE LINE OUTBOUND	RHS EDGE LINE INBOUND	BROKEN CENTRE LINE			CHEVRONS	OTHER LINES	SEAL TYPE	PAINT TYPE	GLASS BEAD TYPE	
			OUTBOUND	INBOUND	INBOUND						
1			1	2	3	1	2	3	1	2	3
2											
3											
4											
5											
6											
7											
8											
9											
10											
Average Reading											
Specification											
Age of Marking											

Note: Attach Location Plan

## **RETROREFLECTIVITY TESTING OF PAVEMENT MARKING WET CONDITION**

### **1. SCOPE**

This procedure describes the method for determining the retro-reflectivity (night visibility) of road markings, in the wet condition.

The method is to be used in conjunction with NTTM 404.1.

### **2. APPARATUS**

- (a) 10 ltr. Bucket;
- (b) 10 ltrs. of potable water;
- (c) Watch.

### **3. SITE SELECTION**

Site selection shall be as specified in NTTM 404.1.

### **4. PREPARATION**

The test condition is created by pouring approximately 10ltrs of water from a bucket on to the test site.

### **5. METHODOLOGY**

Pour from a height of approximately 0.5m above the pavement surface, onto the test site. After 1 minute conduct retro-reflectivity testing in accordance with NTTM 404.1.

### **6. REPORTING**

Report retro-reflectivity test results from both the dry and wet condition. Conform to the requirements of NTTM 404.1.

#### **NOTES ON TEST:**

- 1. The water is poured evenly along the test site, so that a crest of water momentarily floods the test site and its' surrounding area.



## CERTIFICATION OF PAVEMENT LINE MARKING APPARATUS

### 1. SCOPE

This method sets out the procedure for the certification of pavement line marking application apparatus.

### 2. APPARATUS

- (a) Line marking apparatus;
- (b) Wet Film Thickness comb or WFT wheel;
- (c) Metal plates for Wet Film Thickness;
- (d) Plastic bag or tray of at least 3 litres capacity;
- (e) Plastic measuring cylinder with 2-litre capacity graduated in millilitres;
- (f) Watch.

### 3. PROCEDURE

- (a) Set paint pump pressure;
- (b) Set back pressure regulator (if recycle circuit);
- (c) Note settings and stall pressure;
- (d) Note spray tip nozzle sizes;
- (e) Nominate pattern to be calibrated;
- (f) Turn off glass bead supply;
- (g) Check application for nozzle wear and replace if necessary. (e.g. uneven application or feathered edges);
- (h) Check pattern spray width against spec and adjust if necessary;
- (i) Nominate application road-speed;
- (j) Check Wet Film Thickness in accordance with NTTM 401.1, (a WFT 'wheel' may be found more accurate than a 'comb');
- (k) Adjust application speed to meet target wft;
- (l) Repeat steps (i) to (k) until target is achieved;
- (m) Spray at identified speed and check length and gaps of pattern. Adjust if necessary;
- (n) Turns glass bead supply on;
- (o) Set bead – tank pressure;
- (p) Using NTTM 402.1, calibrate to suit pattern and proposed application road speed;
- (q) Apply full application to test deck and visually check for alignment and uniform application of paint and glass beads;
- (r) Repeat above steps (a) to (q) for various patterns and dimensions.

Table 1 shows the correct volumes of glass beads required to give an application rate on the marked line of approximately 0.30 kg/m<sup>2</sup> for different line widths and road speeds. The glass bead volume figures given in the table are calculated for an actual application rate of 0.34kg/m<sup>2</sup>. These figures are used for calibrating the machine because there is a loss of beads between the bead dispenser and the marked line and the volume is measured with beads not compacted.

**TABLE 1 - VOLUME IN GLASS BEADS (mL) REQUIRED IN 10 SECONDS OF OPERATION**

ROAD SPEED		LINE WIDTHS			
km/h	m.p.h.	75mm (3")	100mm (4")	125mm (5")	150mm (6")
8	5	371	495	619	1207
13	8	603	804	1006	1207
16	10	742	990	1238	1484

Table 2 shows the volumes of Type 3 large glass beads required to provide a **retained** application rate on the lane of approximately 0.400 kilograms / square metre for a variety of line pattern widths and application road speeds.

The following table is to be used for a bead application rate at 0.4 kg/m<sup>2</sup>.

**TABLE 2 - VOLUME OF TYPE 3 LARGE GLASS BEADS (mL) REQUIRED IN 10 SECS OF OPERATION**

Millilitres Of Large Glass Beads / 10 Seconds			
Line Width	100mm	150mm	200mm
Road Speed			
5 km/hr	370	550	740
6 km/hr	450	660	890
7 km/hr	520	780	1040
8 km/hr	590	890	1180
9 km/hr	660	1000	1340
10 km/hr	740	1110	1480
11 km/hr	820	1220	1630
12 km/hr	890	1340	1780
13 km/hr	960	1440	1930
14 km/hr	1040	1550	2070
15 km/hr	1110	1660	2220
16 km/hr	1180	1780	2370

#### 4. REPORTING

- (a) Report the following:
- (b) Produce an application chart with pressure settings, nozzle sizes and application road speeds for a variety of patterns as a guide for future operational setups;
- (c) Date of test;
- (d) Location of test;
- (e) Testing officer.

#### **NOTES ON TEST:**

1. The maximum application speed is 12km/hr;
2. Each calibration should establish the % of beads lost during application in order to achieve the retained target, and then calibrate the dispensing quantity to suit;
3. Low pressure or gravity delivery to a gravity dispenser will produce the best application results;
4. The figures above are for the specified RETAINED bead application rate of 0.4 kg/m<sup>2</sup>;
5. There is no allowance for loss of glass beads during the application process Roadmarking Operators should establish the % of beads lost during application and calibrate to suit the application retained rate.

## INDEX OF TEST METHODS

TEST METHOD	SECTION 5 - SAMPLING & TESTING BITUMEN AND RELATED PRODUCTS	PAGE NUMBER
NTTM 500.1	Certification of Bitumen Sprayers	2

## CERTIFICATION OF BITUMEN SPRAYERS FOR USE ON NORTHERN TERRITORY ROAD PROJECTS DIVISION PROJECTS

### 1. SCOPE OF CALIBRATION

This test method sets out the tests and procedures for the calibration of bitumen sprayers.

This calibration method does not apply to the initial calibration of a bitumen sprayer. The calibration of an extensively modified bitumen sprayer is beyond the scope of this test method.

This test method must be carried out under the supervision of an authorised Departmental representative.

This test method uses selected tests from "Bitumen Sprayers", NAASRA 1989 (NOTE: 1). this method is an interim calibration method to be used until the Department adopts the Austroads SDT series test methods.

### 2. APPARATUS

#### i. Distribution Trough

The minimum requirements for the trough are:

- (a) The total volume of calibration fluid sprayed must be collected in the trough.
- (b) This trough must permit the sprayed calibration fluid to be separated transversely into 50mm sections, over the full width of spray.
- (c) The trough design must permit the measurement of the quantity of calibration fluid in each 50mm section by an approved means, e.g. Northern Territory Weights and Measures approved dipsticks and conversion tables, depth to volume.

#### ii. Stopwatch

A stopwatch with an accuracy of  $\pm 1$  sec.

#### iii. Torch

#### iv. Calibration Fluid

Fluid with:

- (a) a Kinematic viscosity of  $80 \times 10^{-6} \text{ m}^2/\text{s}$  to  $110 \times 10^{-6} \text{ m}^2/\text{s}$ ;
- (b) a density of 0.85 - 0.94 g/mL, and;
- (c) a Dynamic Viscosity of 0.07 Pa.s to 0.1 Pa.s.

### 3. PREPARATION

(a) Calibration Fluid

Viscosity and density testing are to be carried out in accordance with AS 2341, by an organisation with a Quality Assurance Procedure (Q.A.P.) and/or NATA registration for these tests acceptable to the Department.

The calibration certificate for the calibration fluid is valid for one month from the date of calibration. Spray wagon calibration shall not proceed until the calibration fluid is within acceptable limits.

(b) Motor Vehicle Act 1985;

- i. The Spray Wagon Owner shall supply a copy of the current Motor Vehicle Registration Certificate for inclusion in the calibration report.
- ii. Record the bitumen sprayer owner's plant identity number for inclusion in the calibration report.

(c) Temperature Gauges

- i. The Spray Wagon Owner shall supply a thermometer with a range 0 – 250 °C and readable to 5°C with a current calibration acceptable to the Department. The calibration should not be older than 2 years.

(d) Bitumen Sprayer Dipstick

- i. Inspect the dipstick for any damage which would affect its calibration. Ensure that the owner's plant identity number is engraved on the dipstick.

(e) Bitumen Sprayer Tank

- i. Inspect the interior of the empty tank for any obvious damage which would affect the calibration of the dipstick (NOTE: 2).
- ii. Record the safe filling level tank capacity for inclusion in the calibration report.
- iii. Record the total tank capacity for inclusion in the calibration report.

(f) Spray Nozzles

- i. All spray nozzles shall comply with the requirements of "Bitumen Sprayers", (NAASRA) 1989.
- ii. Record the type of all spray nozzles for inclusion in the report.
- iii. Inspect all nozzles to identify if previously used or unused. Record the date and any other information stamped on nozzles.
- iv. Unused Nozzles: will be deemed to comply for 24 months after successful completion of all distribution tests. (NOTE: 3)
- v. Used Nozzles: may be used if calibrated by an Authority acceptable to the Department within the previous 6 months of the commencement of this calibration. These nozzles will be deemed to comply for 24 months after successful completion of all distribution tests. (NOTE: 3). A copy of the calibration certificate for the nozzles shall be supplied prior to the calibration of the spray wagon.

- (g) Spray bar
  - i. Ensure the spray bar is located over the centre line of the distribution trough.
  - ii. Ensure the spray bar is level.
  - iii. Ensure the front face of the spray nozzles is parallel to the centre line of the spray bar.
  - iv. Record the spray bar type for inclusion in the calibration report.

#### 4. PROCEDURE

- (a) Ensure the trough is empty.
- (b) Ensure all trough stopcocks are closed.
- (c) Ensure the spray bar is full.
- (d) Record the difference in height of the lowest point of the spray nozzles and the top of the trough.
- (e) Record the volume of calibration fluid within the bitumen sprayer tank prior to testing, with bar circulating.
- (f) Record over which 50mm sections the end spray nozzles are located.
- (g) Record the pump speed during bar circulation of the calibration fluid.
- (h) Record the manifold pressure during bar circulation of the calibration fluid.
- (i) Instruct the spray wagon operator to commence spraying.
- (j) Using the stopwatch, record the time of commencement of spraying.
- (k) Do not permit the bitumen sprayer operator to adjust the pump speed.
- (l) Record the pump speed during spraying.
- (m) Record the manifold pressure during spraying.
- (n) Record the time of cessation of spraying (approx. 50 seconds). (NOTE: 4)
- (o) After the settling of the calibration fluid (NOTE: 5) in the bitumen sprayer tank, record the volume of the remaining calibration fluid in the tank.
- (p) After the settling of the calibration fluid in the trough, record the height of calibration fluid in each 50mm section of the trough from the marked coloured plates located behind the viewing tubes.

## 5. REQUIREMENTS

### (a) Transverse Distribution Test;

#### i. For a bitumen sprayer with an 8.0m spray bar.

Carry out transverse distribution testing for the following effective spray widths. (NOTE: 6).

	Effective Spray Width	Nozzles A4	EA4I	Total Nozzles	Total Trough Sections
a)	For 8m effective spray width -	76	2	78	160
b)	For 6.2m effective spray width -	58	2	60	124
c)	For 3.7m effective spray width -	33	2	35	74
d)	For 3.8m effective spray width for twin tap -	34	2	36	75

Tank Levels:

- 100 - 80% full;
- 80 - 50% full;
- < 50% full.

#### ii. For a bitumen sprayer with a 4.0m spray bar.

Carry out transverse distribution testing for the following effective spray width.

a)	4.0m – only				
	Effective spray width -	Nozzles A4	EA4	Total Nozzles	Total Trough Sections
	For 4.0m effective spray width-	36	2	38	80

Tank Level:

- 50-80% full.

#### iii. For all spray bar widths.

(b) The acceptable effective spray width shall be:

8.0m spray bar-	7.95 - 8.05m
6.2m spray bar-	6.15 - 6.25m
4.0m spray bar-	3.95 - 4.05m
3.7m spray bar-	3.65 - 3.75m

- No 50mm section is to differ from the mean by more than 20%, except sections **outside** the end jets, which shall be averaged separately.
- Not more than two 50mm sections in any ten consecutive segments to differ from the mean by more than 15%.
- Not more than four 50mm sections in any consecutive seven segments to differ from the mean by more than 10%.



**iv. Testing Frequency**

a)	Calibration Fluid	3 months
b)	T.D.T.	12 months
c)	Spray Nozzles (used Without Calibration Certificate)	12 months
d)	Spray Nozzles (used With Calibration Certificate)	24 months
e)	Spray Nozzles (unused)	24 months
f)	Thermometers	24 months
g)	Pressure Gauge	24 months

**b) Dipstick Calibration Check**

The output calculated from the bitumen sprayer tank dipstick readings must be within  $\pm 50$  litres of the total theoretical volume as calculated.

**6. REPORTING**

- (a) Following successful completion of all tests, a report is to be presented to the Materials Testing Manager for endorsement.
- (b) Report Layout
- i. Title Page;
  - ii. Bitumen Sprayer Calibration Certificate;
  - iii. Completed Quality Control Checklist;
  - iv. Calibration fluid test report;
  - v. Spray nozzle calibration certificate/s (used nozzles);
  - vi. Bitumen Sprayer Registration Certificate copy;
  - vii. Thermometer Calibration Certificate copies, if required;
  - viii. Worksheet 500(a), (Depth recording of every 50mm section of trough);
  - ix. Bitumen Sprayer Calibration Certificate.
- (c)
- i. All original recordings are to be compiled into a report and placed on file;
  - ii. A copy of the Bitumen Sprayer Calibration Certificate is to be supplied to the bitumen sprayer owner. (Calibration Certificate to be endorsed by Materials Testing Manager).

**NOTES ON TEST:**1. **NAASRA**

National Association of Australian State Road Authorities, now known as AUSTROADS.

2. **Bitumen Sprayer Tank**

Obvious dents in the interior walls of the tank will affect the calibration of the dipstick. Where obvious damage is found the dipstick must be recalibrated by an organisation with a Q.A.P. for the recalibration of dipsticks, acceptable to the Department, prior to Transverse Distribution Test commencement.

3. **Spray Nozzles**

If a Bitumen Sprayer is presented for calibration with any uncalibrated used spray nozzles, replace these spray nozzles with new or calibrated spray nozzles.

Engrave the month and year of the commencement of the calibration period, on all spray nozzles. Stamp all engraved spray nozzles once, with the logo stamp punch. Engrave and stamp any new spare nozzles at the Bitumen Sprayer owner's request. Do not re-engage the spray nozzle during the currency of the calibration period.

4. **Duration of Spray**

The duration of spray is approximately 50 seconds. This is only to ensure the trough is used to near its maximum potential without risk of overflowing.

5. **Settling of Calibration Fluid**

The calibration fluid is deemed to be settled when air bubbles have departed from the surface of the calibration fluid.

6. **Effective Spray Width** (E.S.W.)

The E.S.W. shall be the distance over which no individual (50mm section of trough) volume varies from the mean volume by more than 20%.

7. **Western Australian (W.A.) End Nozzles**

Western Australian end spray nozzles may be used. The reduced maximum effective width of spray (usually 0.3m less than the E.S.W. using "Copley" end spray nozzles) must be recorded on the calibration certificate. The mean volume of calibration fluid per 50mm section of trough will be determined by the total volume of fluid in the trough divided by the 'Total Trough Sections' figure presented in the Table in 5 (a) minus six (0.3m/50mm). Example 8.0m E.S.W. is reduced to 7.7m and the total volume of fluid is divided by (160-6) 154.

Or;

To maintain the effective spray width to 8.0m using WA end jets, increase the bar length by adding 3 X A4 type jets.

8. **Currency of Calibration Certificate**

Consecutive 12 month calibrations using the same spray nozzles shall be issued for a **maximum combined period of 2 years from the initial calibration of the nozzles. Calibration certificates for spray wagons using previously used nozzles will be issued for the remaining life of the nozzles, ie Nozzles that were calibrated and stamped 15 months previous will only be valid for 9 months from the consequent calibration, (total nozzle life 24 months).**

9. **Calibration Trough**

A suitable calibration trough is available at the CSR Depot at Tivendale Road, Berrimah.

**CALIBRATION OF BITUMEN SPRAYERS  
TEST RESULTS ON CALIBRATION FLUID**

TO:

REPORT NO:

ATTENTION:

Your request dated ..... and signed by ..... has been received at the laboratory together with the samples.

All the tests have been carried out as detailed in AS 2341, and the classification limits for cutback bitumen have been obtained from, AS2158.

The following information was supplied relating to the samples:

FEATURES:

CONTRACTOR:

SUPPLIERS IDENT.:

PROJECT:

SAMPLED BY:

LOCATION:

DATE SAMPLED:

LAB. REF. NO.

Test results and classification limits are set out below:

PROPERTY	TEST RESULTS	CLASS. MIN.	LIMITS MAX.
Dynamic Viscosity of 25°C Pa.s.			
Kinematic Viscosity mm <sup>2</sup> /s		80	110
Density at 25°C		0.85	0.94

Prepared by: .....

**NORTHERN TERRITORY**

**BITUMEN SPRAYER CALIBRATION CERTIFICATE**

The sprayer described hereunder is hereby certified as complying with the Construction Division's requirements for Bitumen Sprayers and subject to the conditions endorsed on this Certificate, is authorised to be used for bituminous surfacing works undertaken by or for the Division.

The Division reserves the right to carry out any testing covered in NTTM 500.1 and or "Bitumen Sprayers" NAASRA 1989, during the currency of this certificate.

- Identification of Sprayer :
- Registered Owner of Sprayer :
- Vehicle Registration No. :
- Make of Vehicle on which Sprayer is mounted :
- Tank Capacity :
- Tank Capacity Safe Filling Level :
- Dipstick No :
- Spray Bar Type :
- Type and Size of Nozzles :
- End Jet Type :
- Spray Nozzle Stamp Date :
- New Spray Nozzle's will be required on :
- Thermometer 1 Serial Number :
- Thermometer 2 Serial Number :
- Height of Nozzle above Ground :
- Certificate No** :
- Maximum Effective Spray Width** :
- This Certificate Expires On** :

.....  
for Manager Construction Division

This Certificate in no way removes the responsibility of the owner of the Sprayer to ensure compliance at all times with legal requirements, covering the vehicle and its equipment, applicable to the Territory and State in which the vehicle is operated and is issued subject to the Sprayer continuing to operate satisfactorily and may be cancelled at any time

**CALIBRATION OF BITUMEN SPRAYERS  
TRANSVERSE DISTRIBUTION TEST**

COMPANY:  
IDENTIFICATION OF SPRAYER:  
REGISTRATION NO:  
VEHICLE MAKE:  
TANK CAPACITY:  
DIPSTICK NO:  
BAR TYPE:  
SPRAY NOZZLES:

DATE:  
TIME:  
DIPE. REP:  
COMPANY REP:  
SPRAYER OPERATOR:  
ON SITE:  
LEFT SITE:  
SPRAY WIDTH:

---

SEG.	DEPTH	SEG.	DEPTH	SEG.	DEPTH	SEG.	DEPTH	SEG.	DEPTH	SEG.	DEPTH
1.	_____	31.	_____	61.	_____	91.	_____	121.	_____	151.	_____
2.	_____	32.	_____	62.	_____	92.	_____	122.	_____	152.	_____
3.	_____	33.	_____	63.	_____	93.	_____	123.	_____	153.	_____
4.	_____	34.	_____	64.	_____	94.	_____	124.	_____	154.	_____
5.	_____	35.	_____	65.	_____	95.	_____	125.	_____	155.	_____
6.	_____	36.	_____	66.	_____	96.	_____	126.	_____	156.	_____
7.	_____	37.	_____	67.	_____	97.	_____	127.	_____	157.	_____
8.	_____	38.	_____	68.	_____	98.	_____	128.	_____	158.	_____
9.	_____	39.	_____	69.	_____	99.	_____	129.	_____	159.	_____
10.	_____	40.	_____	70.	_____	100.	_____	130.	_____	160.	_____
11.	_____	41.	_____	71.	_____	101.	_____	131.	_____	161.	_____
12.	_____	42.	_____	72.	_____	102.	_____	132.	_____	162.	_____
13.	_____	43.	_____	73.	_____	103.	_____	133.	_____	163.	_____
14.	_____	44.	_____	74.	_____	104.	_____	134.	_____	164.	_____
15.	_____	45.	_____	75.	_____	105.	_____	135.	_____	165.	_____
16.	_____	46.	_____	76.	_____	106.	_____	136.	_____	166.	_____
17.	_____	47.	_____	77.	_____	107.	_____	137.	_____	167.	_____
18.	_____	48.	_____	78.	_____	108.	_____	138.	_____	168.	_____
19.	_____	49.	_____	79.	_____	109.	_____	139.	_____	169.	_____
20.	_____	50.	_____	80.	_____	110.	_____	140.	_____	170.	_____
21.	_____	51.	_____	81.	_____	111.	_____	141.	_____	171.	_____
22.	_____	52.	_____	82.	_____	112.	_____	142.	_____	172.	_____
23.	_____	53.	_____	83.	_____	113.	_____	143.	_____	173.	_____
24.	_____	54.	_____	84.	_____	114.	_____	144.	_____	174.	_____
25.	_____	55.	_____	85.	_____	115.	_____	145.	_____	175.	_____
26.	_____	56.	_____	86.	_____	116.	_____	146.	_____	176.	_____
27.	_____	57.	_____	87.	_____	117.	_____	147.	_____	177.	_____
28.	_____	58.	_____	88.	_____	118.	_____	148.	_____	178.	_____
29.	_____	59.	_____	89.	_____	119.	_____	149.	_____	179.	_____
30.	_____	60.	_____	90.	_____	120.	_____	150.	_____	180.	_____

-----  
MANIFOLD PRESSURE (BC):  
MANIFOLD PRESSURE (SP):  
PUMP SPEED (BC):  
PUMP SPEED (SP):  
% ERROR:

SPRAY TIME (SECS):  
DIPSTICK BEFORE:  
DIPSTICK AFTER:  
OUTPUT (LTRS):  
THEORETICAL:

**CALIBRATION OF BITUMEN SPRAYERS  
QUALITY CONTROL CHECKLIST  
PLACE INITIAL BESIDE ITEM NUMBER**

1. Calibration fluid viscosity is acceptable & certificate supplied);
  2. Sprayer is registered. (Copy of certificate has been supplied);
  3. Sprayer tank has been inspected and is free of debris and dents;
  4. Instrument calibration certificates supplied;
  5. Trough free of debris and damage;
  6. Nozzles unused and/or calibration certificate checked;
  7. Spray bar set up correctly;
  8. End jets checked. (Extra bar length added if W.A. end jets used);
  9. Dipstick Serial Number matches plant identity number and has been recorded for inclusion on the certificate (Engrave number if none exists);
  10. Trough depth - volume conversion cross-checked with contractor's representative (manual conversion only);
  11. Tank output (dips) - trough quantities, compare within 50 L;
  12. All transverse distribution tests completed;
  13. All 50 mm section outputs meet requirements;
- Unused or calibrated nozzles stamped and dated.

## INDEX OF TEST METHODS

TEST METHOD	SECTION 6 - SAMPLING & TESTING CEMENT AND CONCRETE	PAGE NUMBER
NTTM 601.1	Quality Control of Concrete - Wet Analysis	2



## QUALITY CONTROL OF CONCRETE - WET ANALYSIS

### 1. SCOPE

This test method is for determining the moisture content and sieve analysis of freshly mixed concrete. It may be used to give an indication of the cement content of freshly mixed concrete provided the sieve analyses of all the concrete components and that of the cement used are known.

Normally the test will be carried out in two stages, the first being at the point of discharge of the concrete and the second in the laboratory.

### 2. APPARATUS AND PROCEDURE

#### **STAGE 1 (POINT OF DISCHARGE)**

A sample of concrete of about 25 kg shall be obtained from the freshly mixed concrete in accordance with the procedures outlined in AS 1012.1. The sample shall be thoroughly mixed and a 10kg portion (approx.) shall be placed in a previously weighed tray and weighed immediately. The mass of tray and wet sample shall be recorded. The sample should then be protected as necessary for transporting to the laboratory for the determination of moisture content.

A second portion of approximately 10kg mass shall be placed in a weighed dish and the mass recorded. Water shall then be added to the dish and the concrete thoroughly mixed, allowed to stand for 15-20 seconds and the water and cement poured off through a 75 /um AS Sieve. This process of elutriation shall be repeated at least twice. The portion retained on 75/um sieve should be added to the sample. The sample should then be protected as necessary for transporting back to the laboratory.

#### **STAGE 2 (IN LABORATORY)**

The moisture content sample shall be dried out as quickly as possible over a gas ring or similar heat source. The sample shall be considered to be fully dried out when two successive weighings, at least 30 minutes apart, are the same. Record the dry mass of the sample, plus tray.

The second portion shall be further elutriated until the wash is clear. The 75 um Sieve residue shall be washed back into the dish and the dish and its contents dried out in an oven at 105°C - 110°C until drying is complete.

When the sample is dry, a mechanical analysis shall be carried out in accordance with AS1141.11. Also the ratio of the moisture content to the material passing the 75 um Sieve shall be reported, as shall be the slump of the concrete sample.

### 3. COMMENTS ON APPLICATION OF TEST

1. Good reproducibility in the grading of freshly mixed concrete can be obtained by this procedure for the analysis of wet concrete. For correct interpretation of the results however, especially percentage passing the 75 um Sieve, the grading of the aggregates and cement used must be known.
2. Experience has indicated that four hours directly over a gas burner is required to determine the moisture content accurately, and also that the correct moisture content can only be determined if the interval between initial mixing and commencement of drying does not exceed one hour.

3. The benefits of using Wet analysis as an auxiliary to the usual quality control in the field are as follows:-
- The analysis will indicate serious departures from the specified grading, particularly when dealing with concrete batch plants that have small stockpile reserves which prevent pre-testing.
  - The analysis will indicate immediately any appreciable weighing fault in the batching system.
  - Perhaps the most important aspect is the constant check on the water content, which will indicate if the assessment of the aggregate moisture contents is correct and also provides a check on the water gauge.

## INDEX OF TEST METHODS

TEST METHOD	SECTION 7 – PAVEMENT TESTING	PAGE NUMBER
NTTM 701.1	Benkleman Beam Testing Methodology	2
NTTM 702.1	Field Permeameter testing of Bituminous Seals	7

## BENKELMAN BEAM DEFLECTION TEST

### 1. SCOPE

This test method sets out the procedure for measuring the deflection of a flexible pavement using the Benkelman Beam.

### 2. APPARATUS

- (a) Benkelman beam apparatus fitted with a suitable vibrator.
- (b) Truck:
  - i. Load: The vehicle must have an  $8.2 \pm 0.2$  tonne load over the rear axle equally distributed by each set of dual wheels. The rear axle mass of the test vehicle shall be determined with full tanks of fuel and chains on board;
  - ii. Tyres: The following guidelines should be followed in respect to tyres for Benkelman Beam vehicles. These requirements apply to the tyres on the dual wheels of the ballasted axle;
    - Size: 10 x 20, preferably 12 ply but higher ply ratings are acceptable, i.e. 14 ply;
    - Construction: Diagonal ply (i.e. cross ply or bias ply);
    - Tread Pattern: "Highway" type. Lug type not acceptable;
    - Pressure: 550 kPa  $\pm$  10 kPa;
    - Spacing: Tyres should be 300 mm apart, measured centre to centre of the dual wheels;
    - Wear: It is essential that all four tyres on the rear axle show the same degree of wear.
  - iii. Tyre pressure gauge
    - (a) Thermometer (0-100°C) with 1<sup>0</sup> divisions;
    - (b) Asphalt hole punch and light oil;
    - (c) 10m tape;
    - (d) Notebook, worksheets;
    - (e) Camera.

### 3. DEFINITION

The rebound deflection bowl is the shape of the deflection profile as the truck moves off the test point. It is determined from measurements of deflection using the Benkelman Beam, at 0mm, 300mm, 600mm, 900mm and 2700mm and 6000mm spacings.

### 4. PREPARATION

- i.
  - Obtain truck capable of carrying 8.2t over the back axle, with correct axle tyre configuration;
  - Ensure truck has chains and blocks for securing load;
  - Check tyre pressure;
- ii. Arrange for a forklift or crane to load the ballast to equal 8.2t;

- ii. Ensure the distribution of 4.1t load over near wheel by measuring with mobile scales or otherwise.
- iii. Benkelman Beams
  - Ensure beams are calibrated;
  - Ensure both beams are functioning satisfactory;
  - Ensure dial gauges are working;
  - Ensure that the dial gauge vibrators are functioning.
- iv. Traffic Control
  - Arrange suitable traffic control measures, including staff, signs, flashing lights and radios where required.
- v. Staff
  - 1 x distance measure and caller;
  - 1 x Truck Driver;
  - 2 x Beam Operators.
- vi. Conduct test run to ensure all equipment is functioning correctly.

## 5. SETTING OUT

Include the following information in the report: -

- i. Pavement Temperature;
- ii. Air Temperature;
- iii. Thickness of asphaltic concrete layer, if appropriate.
- iv. Road name;
- v. Road number from PRP Register;
- vi. Lane No. Inbound or Outbound;
- vii. Date and Time;
- viii. Test location, chainage, wheel path, distance and pavement width.

Lanes are numbered from left to right, looking in the direction of traffic flow with lane 1 being the outer or slow lane. Where there is a change in the number of lanes over the length under test, care must be taken to indicate the direction and lane number. A sketch plan is to accompany the test results.

Spacing of the test sites should be such that at least 10 measurements are taken in each length over which the pavement and surrounding conditions appear uniform. The spacing of the test sites is dependent on the length and uniformity of the section and the following table below may be used as guide:

- 10m for all construction control testing, otherwise;
- 25m for section length less than 1 km;
- 50m for section length between 1 to 2km;
- 100m for section length between 2-5km;
- 200m for section length more than 5km.

- iv. Deflections shall be measured in the wheel paths.

**6. PROCEDURE**

- (a) Select and mark the point on the pavement, which is to be tested. See Note 1;
- (b) Centre the dual wheels of the truck approximately 1.5m behind the selected test site;
- (c) Insert the probe of the Benkelman beam between the dual wheels and place it on the selected test site (1.5m from the tip of the beam to the axle), ensuring that the tyres of the truck will not touch the beams;
- (d) Remove the locking pin from the beam and adjust the rear leg until the dial gauge is in the midrange of its travel;
- (e) Turn on the vibrator;
- (f) Set the dial gauge at zero;
- (g) Creep the truck slowly forward and take readings of the Benkelman beam gauge as the truck moves past the zero point, 200mm, 400mm, 600mm, 900mm, 1,200mm and 1,500mm spacings. Stop the truck 2.7m from the zero point and record the gauge reading when the rate of recovery is equal or less than 25 $\mu$ m per minute;
- (h) Drive the truck forward to 6m and record the gauge reading when the rate of recovery is equal or less than 25 $\mu$ m per minute;
- (i) Turn off the vibrator;
- (j) For asphaltic concrete pavement, record the pavement temperature and air temperature at least once every hour;
- (k) Record the air and road temperature approximately every 1-2 hours;
- (l) At each test site record and rate the pavement shape and condition including the surface type and any cracking etc.

**NOTES:**

1. The truck should be parked for a minimum period of 3 minutes and the entire test shall be completed within approximately 4 minutes;
2. Check the truck tyres every 2-3 hrs and if necessary adjust to specified pressure;
3. For chip seal surfaces pavement temperature is not required.

**7. DATA COLLECTION**

- (a) Obtain traffic data records (if required) such as:
  - traffic counts;
  - percent commercial vehicles;
  - traffic distribution;
  - past traffic;
  - future traffic predictions.
- (b) Obtain information on the pavement configuration from previous records or conduct pavement dippings.

## 8. DATA ANALYSIS

### 8.1 Analysis of Field Data

Analyse the data to break the subject section of road into areas with similar values.

### 8.2 Required Deflection Data

Determine the maximum deflection:	(2 x dial gauge reading at 0mm distance)
Determine the Datum:	(6000mm reading)
Determine the residual rebound:	(maximum deflection – datum reading x 2) Note: can be + or -
Determine the rebound deflection:	(maximum deflection - residual deflection)
Determine the D300:	(300mm reading - datum) x 2
Determine the D600:	(600mm reading - datum) x 2
Determine the D900:	(900mm reading - datum) x 2
Determine the CBR:	(D900 read off from Chart 5)
Determine the tolerable deflection:	(CBR Vs ESA's from Chart 6)
Determine the D 200:	$\frac{((300\text{mm reading} - 0\text{mm reading})/300) * 200}{1} + 0\text{mm reading}$
Determine the D 250:	$\frac{((300\text{mm reading} - 0\text{mm reading})/300) * 250}{1} + 0\text{mm reading}$

### 8.3 Outliers

(a) Using the following procedure determine if any of the results are outliers.

i. Check for very large values.

Arrange the data in decreasing order, and calculate a statistic,  $\gamma$

$$\gamma = \frac{(\text{max value}) - (\text{next max value})}{(\text{max value}) - (\text{min value})}$$

$$\gamma = \frac{(\text{max}) - (\text{max} - 1)}{\text{max} - \text{min}}$$

If  $\gamma$  exceeds the critical value given below, then discard max. (i.e. is an outlier)

n	3	4	5	6	7	8	9	$\geq 10$
$\gamma$ (n.05)	.941	.765	.642	.560	.507	.468	.437	.412

ii. In a similar way, we can test for very small values.

$$\gamma = \frac{\text{min} + 1 - \text{min}}{\text{max} - \text{min}}$$

again, if  $\gamma$  exceeds the value in the table, then we discard it.

- (b) Remove any outliers from any further calculation and recalculate all values, (with the outliers removed).

#### 8.4 Calculation

Determine if over the full length tested, there are distinct changes in the level of deflection over significant lengths, to warrant splitting up these lengths for separate analysis.

**NOTE:** These variations may be due to changes in surfacing type, pavement thickness, drainage conditions or topography.

After splitting the tested section into significant lengths, calculate the average ( $\bar{u}$ ), standard deviation ( $s$ ), characteristic deflection ( $u+fs$ ) and coefficient of variation (CV) values for each wheelpath and length. Abnormally high or low readings should be omitted from the statistical analysis.

### 9. REPORTING

The following test results and general information shall be included in the report:

- All beam testing field data recordings;
- All deflection data test results;
- Pavement surface and shape recordings;
- Pavement temperature;
- Pavement air temperature;
- Checks for outliers;
- Location plans;
- Photographs;
- Road name;
- Road number from PRP Register;
- Lane no's;
- Inbound / Outbound;
- Test direction;
- Date and time of investigation;
- Test location, chainage and offset;
- Length of project and spacing of test sites;
- Pavement width.



## FIELD PERMEAMETER TESTING OF BITUMINOUS SEALS

### 1. SCOPE

This test method describes the procedure for determining the infiltration rate of pavement surfaces using the Field Permeameter Ring. The test is applicable for thin asphalt and sprayed seal surfaces.

### 2. APPARATUS

Equipment required for the test includes:

- (a) permeameter ring (bronze mould);
- (b) slotted masses for securing the mould (approximately 20kg);
- (c) suitable pavement sealing agents such as road marking paint, bitumen emulsion or potters clay;
- (d) 113mm diameter template for marking the test site;
- (e) potters clay for sealing the gap between the mould and the road surface;
- (f) stop watch for timing the drop in head height;
- (g) squeegee bottle and water, food colouring and detergent for the test;
- (h) worksheets.

### 3. PROCEDURE

The procedure consists of the following steps:

- (a) Select the number and location of test sites to represent the characteristics of the seal being evaluated.
- (b) Remove any dirt or loose material from the area to be tested by brooming and washing down with water, and then mop up any excess water on the surface.
- (c) Place the permeameter on the pavement to ensure that the test surface is relatively flat.
- (d) Mark the outline of the permeameter on the pavement surface with spray paint.
- (e) Using the template, an annulus is marked on the nominated test site leaving an unmarked inner diameter of 113mm for the test (10,000 mm<sup>2</sup> surface area). The annulus of suitable sealant may be made by paint, emulsion or potters clay, depending on which material is best suited to the surface type under the prevailing weather conditions. To assist with drying times, several light applications of a spray paint sealant may be required instead of one heavy application. Other tests areas can also be prepared whilst the sealant dries or sets.
- (f) A thick ring of potters clay is applied to the prepared annulus on the road pavement, ensuring that all surface voids are filled, and a water uniform surface is achieved.
- (g) Place the permeameter centrally onto the prepared ring of potter's clay with the air bleed valve on the highest side of the test site. Ensure that the permeameter is securely seated into the potter's clay and a watertight bond is achieved.
- (h) Place approximately 20 kg of slotted masses onto the permeameter with the slots aligned to allow access to the bleed valve.

- (i) Insert the plastic viewing tube into the permeameter. Ensure the viewing tube is inserted far enough to come in contact with the stop lip of the permeameter.
- (j) The air bleed valve is opened and the prepared water is poured in through the viewing tube to fill the permeameter. When water commences to flow out of the air bleed valve, close the air bleed valve whilst ensuring that all air has been expelled from the permeameter. The water level is then filled up to the desired head height ( $h_1$ ), and the test commences.
- (k) The time interval ( $T$ ) for the water head in the viewing tube to fall from  $h_1$  to  $h_2$  is timed using a stopwatch.
- (l) Using the data obtained, the permeability of the sealed surface can be determined approximately in accordance with Hvorslev falling head formulae given below:

$$k = \frac{\pi D}{11(T)} \ln \frac{h_1}{h_2}$$

- (m) Describe the pavement seal type and condition.

#### 4. REPORTING

Report the initial and final head height, the time taken for the water to drop from the initial to final head height, pavement seal type and condition, the pavement temperature, the infiltration rate, and the permeability as calculated using Hrorlev's and the falling head equations.

#### **NOTES ON TEST:**

1. Use a fine grained potters clay, stoneware grade, e.g. Walkers white. The consistency of the clay may need to be adjusted to ensure adequate workability.
2. Potable water shall be used for the testing, and this shall contain food colouring and approximately one drop of detergent/litre.
3. The level of  $h_1$  is usually 600, 500, 400, and 300mm, and thus the level of  $h_2$ , which is 100mm less than  $h_1$ , would be 500, 400, 300, and 200mm respectively.

## FIELD PERMEAMETER WORK SHEET

<b>PROJECT:</b>						
<b>LOCATION:</b>						
<b>WHEEL PATH:</b>						
<b>DATE:</b>						
<b>TEST No.:</b>						
<b>CHAINAGE:</b>						
<b>OFFSET:</b>						
<b>SURFACE DESCRIPTION:</b>	DGA Asphalt	Seal	DGA Asphalt	Seal	DGA Asphalt	Seal
	OGA Asphalt	Slurry	OGA Asphalt	Slurry	OGA Asphalt	Slurry
	SMA Asphalt		SMA Asphalt		SMA Asphalt	
<b>AGGREGATE SIZE mm:</b>						
<b>THICKNESS mm:</b>						
<b>SURFACE CONDITION :</b>	Corrugations, Depressions , Shoving, Level, Rutting,		Corrugations, Depressions Shoving, Level, Rutting,		Corrugations, Depressions Shoving, Level, Rutting,	
<b>BITUMEN CONDITION:</b>	Very Lively/New, Lively Dull, Hard & Brittle		Very Lively/New, Lively Dull, Hard & Brittle		Very Lively/New, Lively Dull, Hard & Brittle	
<b>SURFACE TEXTURE:</b>	Bleeding, Flushed, Black, Smooth, Matt, Hungry, Very Hungry	Raveling, Stripping, Delaminating	Bleeding, Flushed, Black, Smooth, Matt, Hungry, Very Hungry	Raveling, Stripping, Delaminating	Bleeding, Flushed, Black, Smooth, Matt, Hungry, Very Hungry	Raveling, Stripping, Delaminating
<b>CRACKING:</b>	Block, Crescent Shaped, Crocodile, Diagonal, Longitudinal, Transverse, Meandering,		Block, Crescent Shaped, Crocodile, Diagonal, Longitudinal, Transverse, Meandering,		Block, Crescent Shaped, Crocodile, Diagonal, Longitudinal, Transverse, Meandering,	
<b>CONTRACTOR:</b>						
<b>MANUFACTURER:</b>						
<b>SPEED ZONE:</b>						
<b>TRAFFIC COMPOSITION:</b>						
<b>PAVEMENT TEMPERATURE:</b>						
<b>WEATHER CONDITIONS:</b>						
<b>LOCAL SITE DRAINAGE:</b>						
<b>COMMENTS ON SITE CONDITIONS:</b>						
<b>TEST No:</b>						
<b>DROP IN HEAD HEIGHT</b>	<b>CLOCK</b>	<b>ELAPSED TIME</b>	<b>CLOCK</b>	<b>ELAPSED TIME</b>	<b>CLOCK</b>	<b>ELAPSED TIME</b>
h1 600 - h2 500 mm *						
h1 500 - h2 400 mm						
h1 400 - h2 300 mm						
h1 300 - h2 200 mm						
<b>INFILTRATION RATE: *</b>						
<b>COMMENTS ON TEST:</b>						

## INDEX

SECTION 8 – AUSTRALIAN STANDARD TEST METHODS	PAGE NUMBER
Australian Standard Test Methods	2

## AUSTRALIAN STANDARD TEST METHODS

Method No.	Method
AS 1012	Methods of Testing Concrete
AS 1074	Steel Tubes and Tubulars for Ordinary Service
AS 1111	ISO Metric Hexagon Bolts and Screws
AS 1112-1	Style 1 Product Grades A & B
AS 1112-2	Style 2 Product Grades A & B
AS 1112-3	Product Grade C
AS 1112-4	Chamfered Thin Nuts Product Grades A & B
AS 1141	Methods for Sampling and Testing Aggregates
AS 1160	Bituminous Emulsions for the Construction and Maintenance of Pavements
AS 1163	Structural Steel Hollow Sections
AS 1231	Aluminium and Aluminium Alloys – Anodic Oxidation Coatings
AS 1252	High Strength Steel Bolts with Association Nuts & Washers for Structural Engineering
AS 1273	Unplasticised PVC (UPVC) Downpipe and Fittings for Rainwater
AS 1289	Methods of Testing Soils for Engineering Purposes
AS 1302	Steel Reinforcing Bars for Concrete
AS 1304	Welded Wire Reinforcing Fabric for Concrete
AS 1345	Identification of the Contents of Pipes, Conduits and Ducts
AS 1379	Specification and Supply of Concrete
AS 1397	Steel Sheet and Strip-hot Dipped Zinc Coated or Aluminium / Zinc Coated
AS 1477	PVC Pipes and Fittings for Pressure Applications
AS 1478	Chemical Admixtures for Concrete, Mortar and Grout
AS 1554	Paints and Related Materials – Methods of Test
AS 1580	Structural Steel Welding
AS 1594	Hot Rolled Steel Flat Products
AS 1597	Precast Reinforced Concrete Box Culverts
AS 1672	Limes and Limestones – Limes for Building
AS 1722	Pipe Threads of Whitworth Form
AS 1725	Galvanised Rail-less Chain Wire Security Fences and Gates
AS 1734	Aluminium and Aluminium Alloys – Flat Sheet, Coiled Sheet and Plate
AS 1742	Manual of Uniform Traffic Control Devices: Part 3 – Traffic Control Devices for Works Roads
AS 1743	Road Signs – Specifications
AS 1744	Forms of Letters and Numerals for Road Signs

## AUSTRALIAN STANDARD TEST METHODS

Method No.	Method
AS 1761	Helical Lock – Seam Corrugated Steel Pipes
AS 1762	Helical Lock – Seam Corrugated Steel Pipes – Design and Installation
AS 1906	Retroreflective Materials and Devices for Road Traffic Control Purposes
AS 2008	Residual Bitumen for Pavements
AS 2009	Glass Beads for Road Marking Materials
AS 2041	Buried Corrugated Metal Structures
AS 2053	Conduits and Fittings for Electrical Installations
AS 2144	Traffic Signal Lanterns
AS 2157	Cutback Bitumen
AS 2187	Explosives – Storage Transport and Use
AS 2276	Cables for Traffic Signal Installations
AS 2339	Traffic Signal Posts and Attachments
AS 2341	Methods of Testing Bitumen and Related Road Marking Products
AS 2349	Method of Sampling Portland and Blended Cements
AS 2350	Method of Testing Portland and Blended Cements
AS 2353	Pedestrian Push Button Assemblies
AS 2357	Mineral Fillers for Asphalt
AS 2423	Galvanised Wire Fencing Products
AS 2433	Plastics – Method for Exposure to Ultraviolet Lamps
AS 2439	Perforated Plastic Drainage and Effluent Pipe Fittings
AS 2700	Colour Standards for General Purposes
AS 2703	Vehicle Loop Detector Sensors
AS 2758	Aggregates and Rock for Engineering Purposes - Part 1 – Concrete Aggregates, Part 2 – Aggregate for Sprayed Bituminous Surfacing
AS 2809	Road Tank Vehicles for Dangerous Goods
AS 2876	Concrete Kerbs and Channels (Gutters) – Manually or Machine Placed
AS 2891	Methods of Sampling and Testing Asphalt
AS 2979	Traffic Signals Mast Arms
AS 3000	Electrical Installations (Known as the Australian/New Zealand Wiring Rules)
AS 3100	Approval and Test Specification – General Requirements for Electrical Equipment
AS 3108	Approval and Test Specification – Particular Requirements for Isolating Transformers and Safety Isolating Transformers
AS 3155	Approval and Test Specification – Electrical Cables – Thermoplastic Insulated for Working with High Voltages up to and including 0.6/kV
AS 3191	Approval and Test Specification – Electric Flexible Cords
AS 3568	Oils for Reducing the Viscosity of Residual Bitumen for Pavements
AS 3600	Concrete Structures
AS 3610	Formwork for Concrete
AS 3678	Structural Steel – Hot-Rolled Plates, Floor Plates and Slabs
AS 3679	Structural Steel – Part 1 – Hot-Rolled Bars and Sections

## AUSTRALIAN STANDARD TEST METHODS

Method No.	Method
AS 3706	Geotextiles – Methods of Test
AS 3725	Loads on Buried Concrete Pipes
AS 3730.14	Guide to the Properties of Paints for Buildings – Part 14 – Undercoat-Solvent-Borne, Exterior / Interior
AS 3972	Portland and Blended Cements
AS 4025.1	Paints for Equipment including Ships – Solvent –Borne-Interior and Exterior-Full Gloss Enamel
AS 4049.1	Paints and Related Materials – Road Marking Materials – Solvent-Borne Paint – For use with Drop-On Beads
AS 4058	Precast Concrete Pipes (Pressure and Non-pressure)

**SECTION 9 – NOT USED**



**SECTION 10 – NOT USED**