

* 250 HIGH x 230 WIDE x 10 DEEP
2mm GALV. SHEET STEEL POCKET
WELDED TO INSIDE OF DOOR.

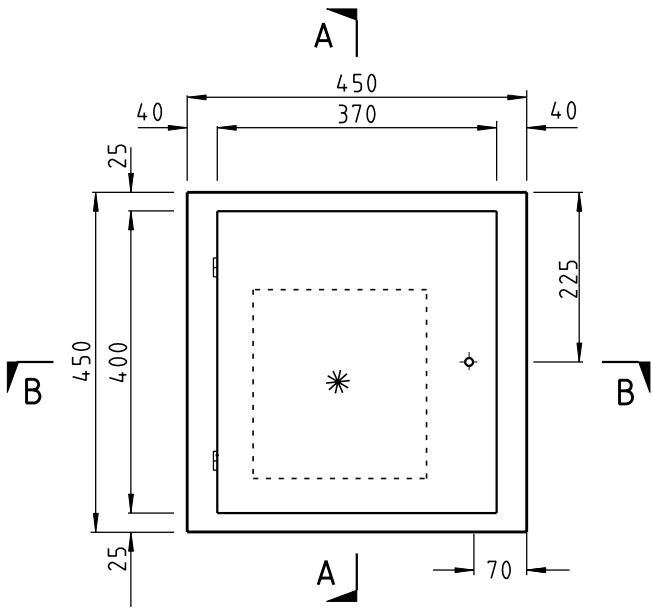

FRONT ELEVATION
NOT TO SCALE

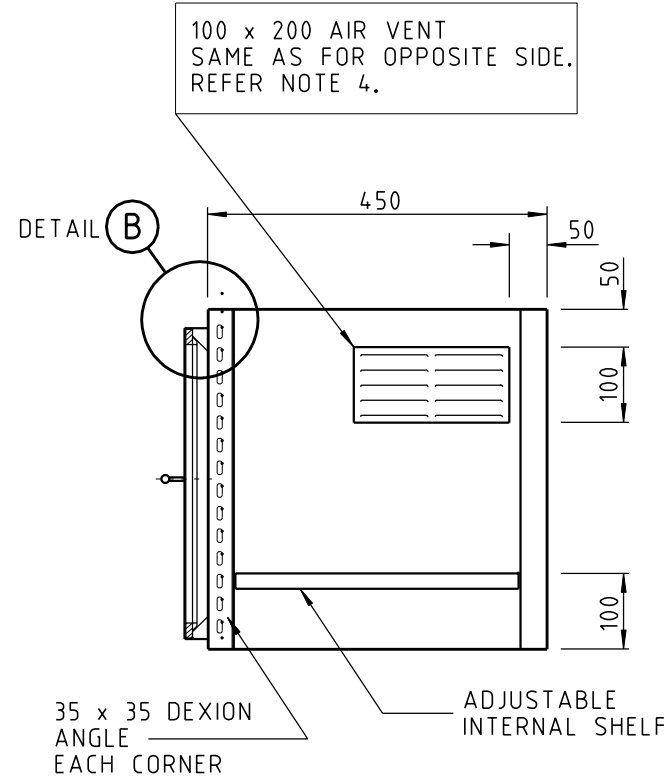

SECTION A-A
NOT TO SCALE

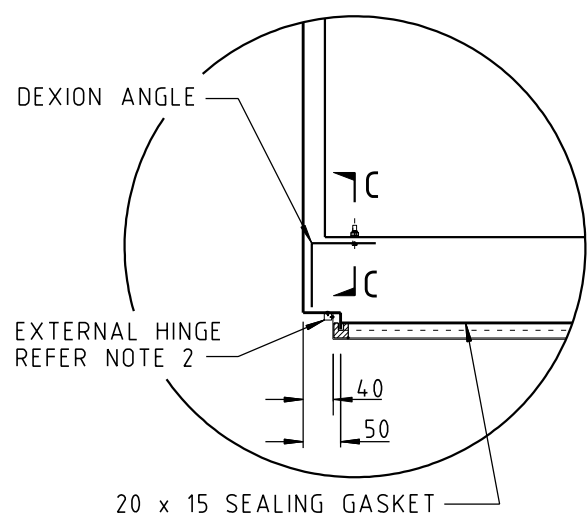

DETAIL A
NOT TO SCALE

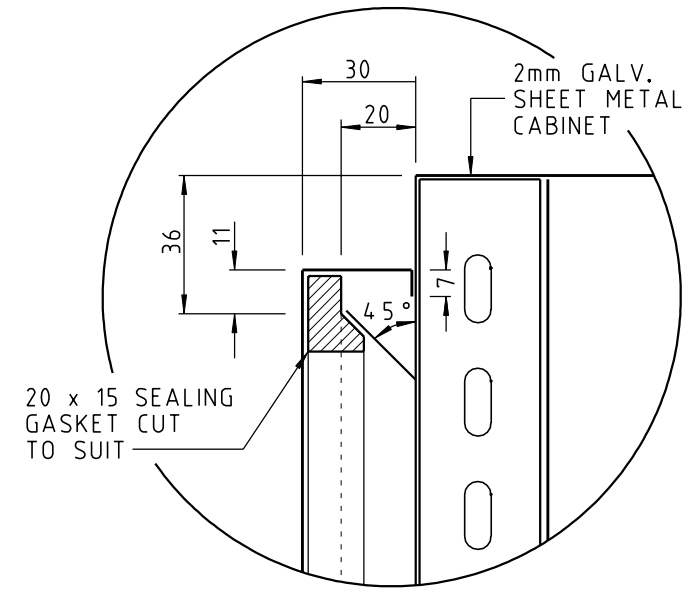

DETAIL B
NOT TO SCALE

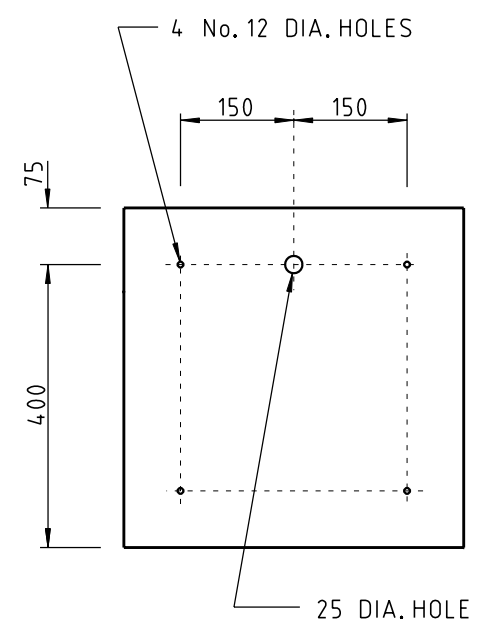

REAR ELEVATION
NOT TO SCALE

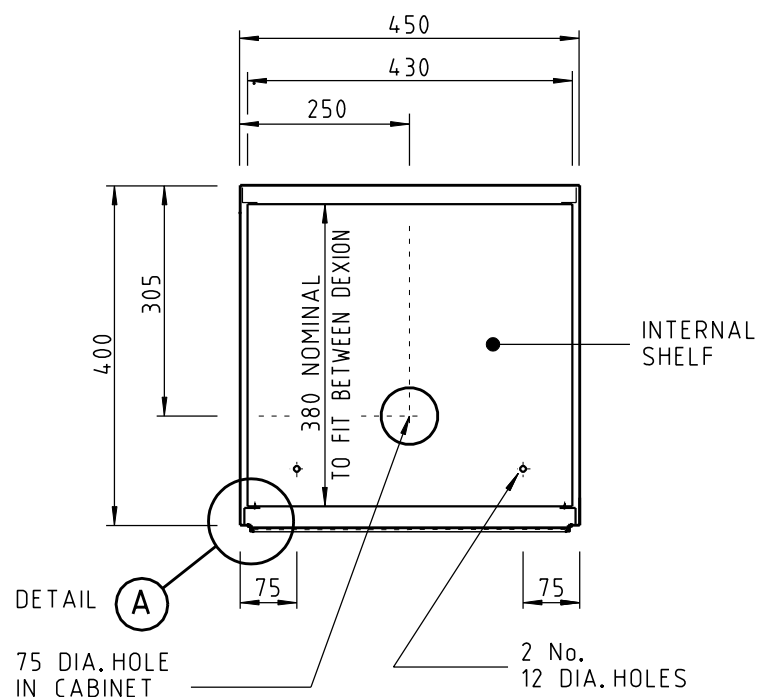

SECTION B-B
NOT TO SCALE

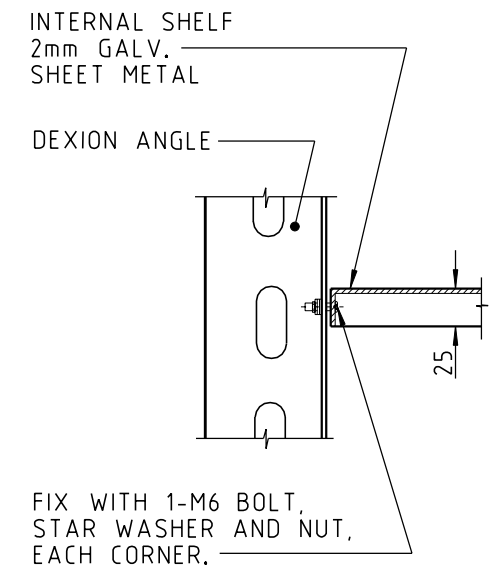

SECTION C - C
NOT TO SCALE

NOTES

- CABINET TO BE CONSTRUCTED FROM 2mm GALVANIZED SHEET STEEL FOLDED AND WELDED TO A WEATHERPROOF STATE.
- DOOR HINGED ON HEAVY DUTY EXTRUDED BRASS L.O./ REM. PIN (6mm DIA.) TYPE HINGE.
- AN APPROVED DUST FILTER AND INSECT SCREEN TO BE FITTED INTERNALLY TO ALL AIR VENTS. DUST FILTERS AND INSECT SCREENS TO BE REPLACEABLE.
- AIR VENTS SHALL BE AFFIXED TO CABINET WITH APPROVED FITTINGS (e.g. POP RIVETS), AND WEATHERPROOF SEAL SUCH AS SILASTIC OR SIMILAR. TWO TO BE FITTED.
- CABINET SHALL BE ETCHED, PRIMED, UNDERCOATED AND FINISHED WITH PAINT OF APPROPRIATE GRADE :

MEDIUM SEA GREY No. 637 TO ASK 185
ADMIRALTY GREY No. 697 TO ASK 185

TWO COATS ARE REQUIRED.
- DOOR FITTINGS - THREE POINT CHROMED LOCKABLE (KEY 604) T - HANDLE, PROVIDE ROLLERS TO STRIKER BARS.

10/02/2003 13:36 PM X:\NTS\STANDARDS\Traffic\CS1556-1.dgn

1.	GOVERNMENT DEPARTMENT LOGOS CHANGED.	5/2002	K.S.
No.	DESCRIPTION	DATE	INIT.
AMENDMENTS			

WARNING
BEWARE OF UNDERGROUND SERVICES
The locations of underground services are approximate only and their exact position should be proven on site. No guarantee is given that all existing services are shown.

DRAWN	K. SCHULZE	CHECKED	
DATE	1-9-1993	DATE	
DESIGNED		CHECKED	
DATE		DATE	
DESIGN PROJECT LEADER	<i>M. M. M. M.</i>	PROJECT OFFICER	
DATE	29 MAY 2002	DATE	

Northern Territory Government
 Department of Infrastructure, Planning and Environment

STANDARD DRAWING			
TRAFFIC COUNTING STATION - POST MOUNTED			
TRAFFIC CABINET DETAILS			
FILE No.	SHEET No.	DRAWING NUMBER	AMEND. SHEET SIZE
	1 OF 1	C(S)1556	1 A1